

EN
2016 | 07

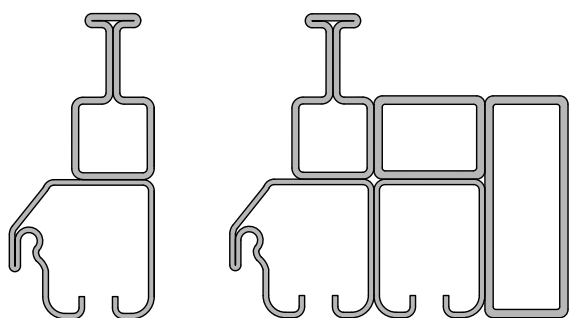

Vario Curtain Sider Roof



Assembly instructions



Contents



Operation 3



Designated use 4



General information 5



Assembly

Front dimensions	8	Inserting sliding pillars	36
Pre-assemble bulkhead	9	Hook in sliding pillars	37
Installing the bulkhead	14	Installing batten pockets	38
Preparing the rear (PWP SA)	16	Installing battens	39
Rear doors (PWP SA)	19	Guide rails	40
Guide rails	20	Preassemble bows	41
Guide rail package	21	Mount bows	42
Installing the guide rails	33	Preassemble end carriage	43
Installing pillar bases	34	Preassemble end bow	45
		Preassemble end carriage / end bow (for use with tarpaulin back cover)	46
		Preassemble end carriage / gantry beam (for use with doors)	47
		Slide up end carriage	48
		End plug / stopper	49
		Rivet folding joints	50
		Mount safety rope	51
		Safety rope – tension	52
		Build roof package	53
		Drill front locking hole	54
		Roof mounted	55





Youtube-Video

Edscha
Trailer Systems

P

$\leq 75 \text{ kg / m}^2$

05/2012 - Nr. 3 807 696 0 www.EdschaTS.com



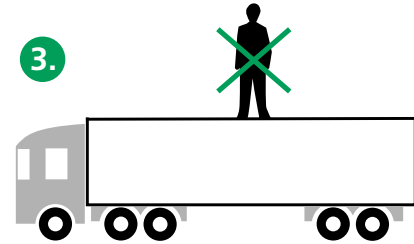
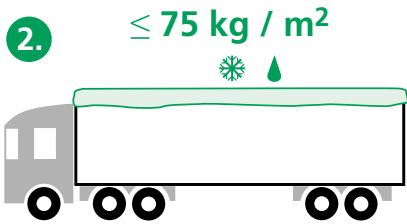
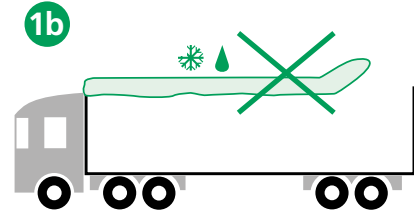
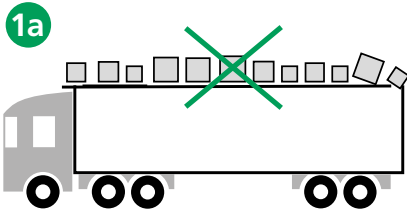

The Edscha Trailer Systems sliding roofs and their operating components are exclusively manufactured for their due employment on truck specific transport operations. Any usage going beyond such applications is considered as misuse. For resulting damages the manufacturer European Trailer Systems GmbH repudiates any liability; for this the user alone bears the full risk. The "intended usage" also includes the observance of the operation, care and maintenance instructions and of the mounting and repair instructions as prescribed by the manufacturer.



The manufacturer, European Trailer Systems GmbH, is discharged from any liability if:

- the Edscha Trailer Systems sliding roof and its components are changed arbitrarily
- EdschaTS original parts are exchanged against other components;
- the Edscha Trailer Systems sliding roof and its operating components are not handled and serviced in compliance with the prevailing Edscha Trailer Systems instructions



All the arising exclusions of risk and liability shall remain valid also if:

- examiners or experts of the technical testing bodies or experts from officially recognised organisations have performed acceptance tests;
- official approval exists.



- **1a 1b Remove roof loads before starting a trip**



- **2 Roof load $\leq 75 \text{ kg / m}^2$**



- **3 Cannot be walked on**

The vehicle equipment supplier is obligated in principle to check whether the products shown satisfy the demands of the user.

© 2016 European Trailer Systems GmbH
www.EdschaTS.com



General information

Structure - planning / preparation

- 1.0 Measure existing vehicle structure
- 2.0 Planning the structural extension
 - 2.1 Taking important legal factors into account:
 - Permitted curb weight / total weight
 - Vehicle dimensions: total height / length / width
 - Laws / traffic safety / insurance / load safety
 - 2.2 Taking important technical factors into account:
 - Vehicle structural analysis
 - Load capacity / material of existing structure
 - Planned vehicle use / loading possibilities



General information

Structure - parameters / requirements

Roof track width (e.g. 2520 mm)

Structural length / height / width (e.g. 13500 x 4000 x 2550 mm)

Rear design (e.g. soft door / doors --> effect on end carriage or gantry beam)

Roof design (CS / VP / fixed posts / sliding posts)

Screws

All screws / nuts with lock / galvanised

	6.8	8.8	10.9
	MA (Nm)		
M4	2,2	3,0	4,4
M5	4,5	5,9	8,7
M6	7,6	10	15
M8	18	25	36
M10	37	49	72
M12	64	85	125
M14	100	135	200
M16	160	210	310
M18	220	300	430
M20	310	425	610
M22	425	580	830
M24	535	730	1050

Tightening torques and rigidity classes (see table)



General information

Vehicle structural analysis - forces / moments

The chassis must be capable of taking up a bending torque ≥ 10 kNm in the area of the front frame
Prerequisite: roof with longitudinal beams

Distance between posts ≤ 3500 mm

The chassis must be capable of taking up a bending torque ≥ 4.5 kNm in the post area
Prerequisite: load capacity ≤ 20 kN / running meter

Front wall rigidity ≥ 500 kN area load (0.4 x load capacity recommended)

The chassis must be capable of taking up a bending torque ≥ 40 kNm in the area of the rear frame
Prerequisite: load capacity ≤ 270 kN

Correct realisation

Tools

Execution of welded seams

Tolerances

Aids

Quality control, tests

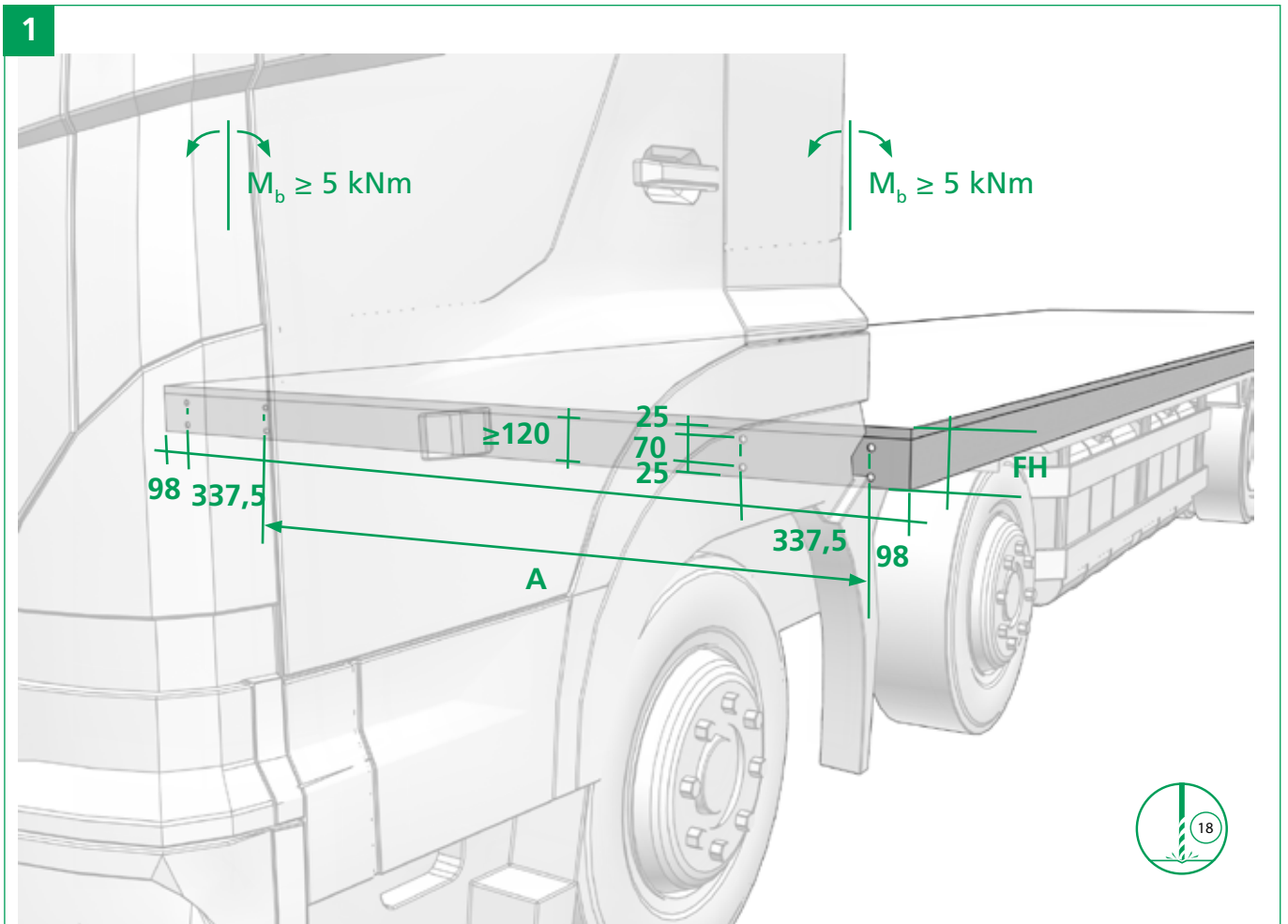

Front dimensions

Process step: Preparation of the base frame

Process: Measurement and drilling

Parameters: Edscha TS bulk head

Material: Edscha TS bulk head

Tools: drilling machine

Aids: Folding rule, centre punch

Preparation: Measurement and drilling

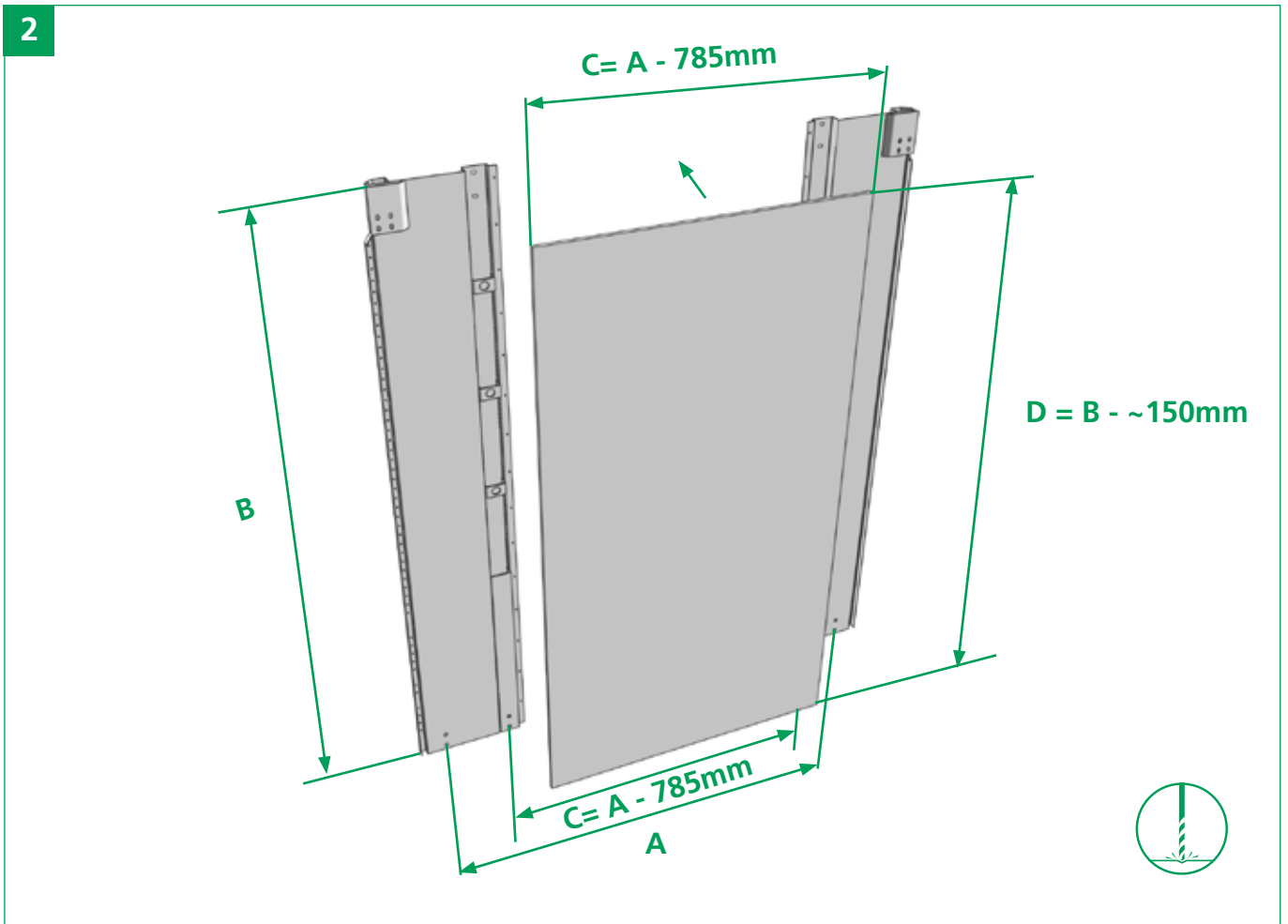

Pre-assembly bulkhead 01

Process step: pre-assemble bulkhead

Process: Mount individually cut front plate

Parameter: Platform width, installation height

Material: Plywood panel, bulkhead elements (2021), screws

Tools: measurement/marketing tools, saw, drilling machine, screw driver

Aids:

Preparation:

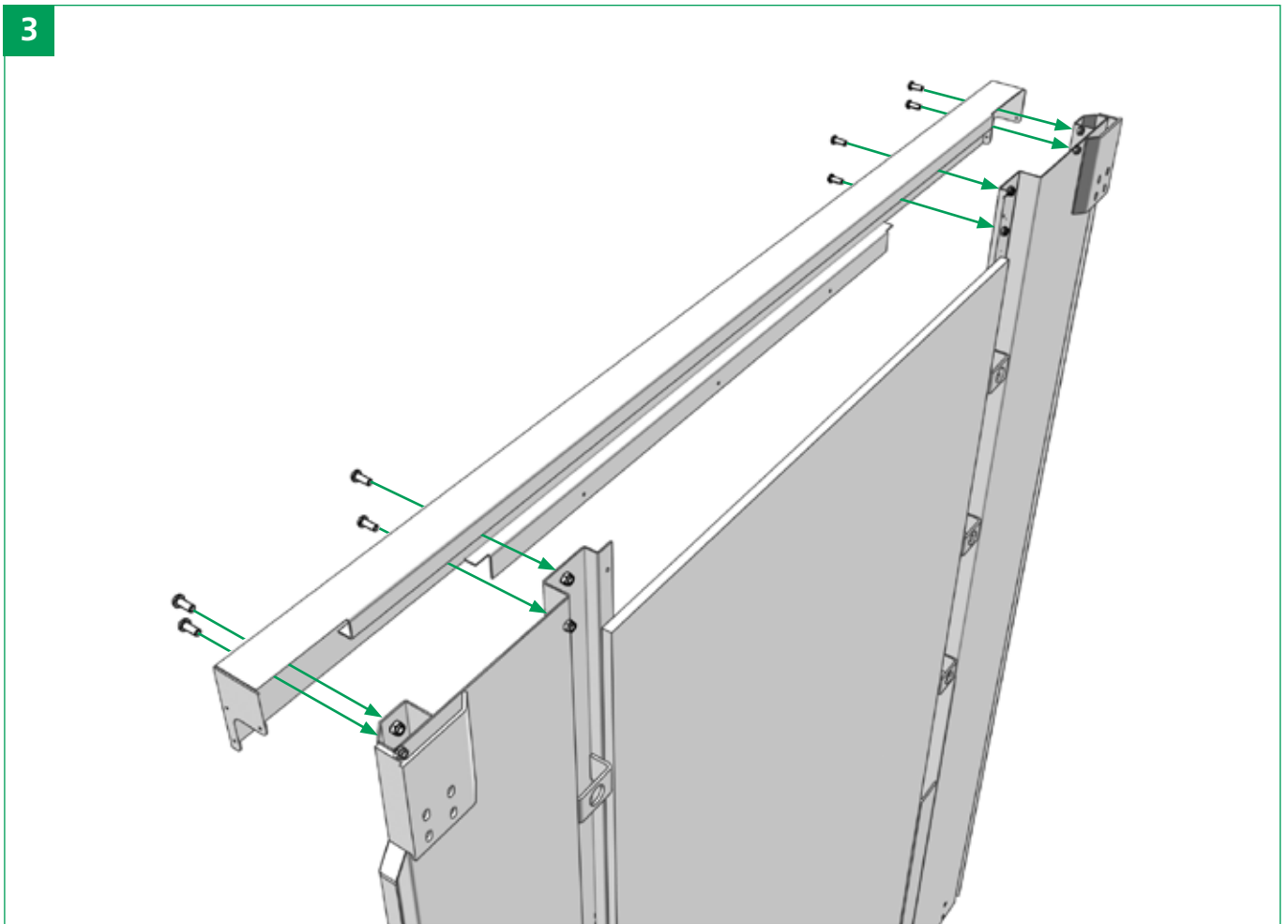

Pre-assemble bulkhead 02

Process step: pre-assemble bulkhead

Process: Mount bulkhead cover (adjust if necessary)

Parameters: Installation width, roof track width

Material: Edscha TS bulkhead cover (2021), screws

Tools: torque wrench, screw driver

Aids:

Preparation:

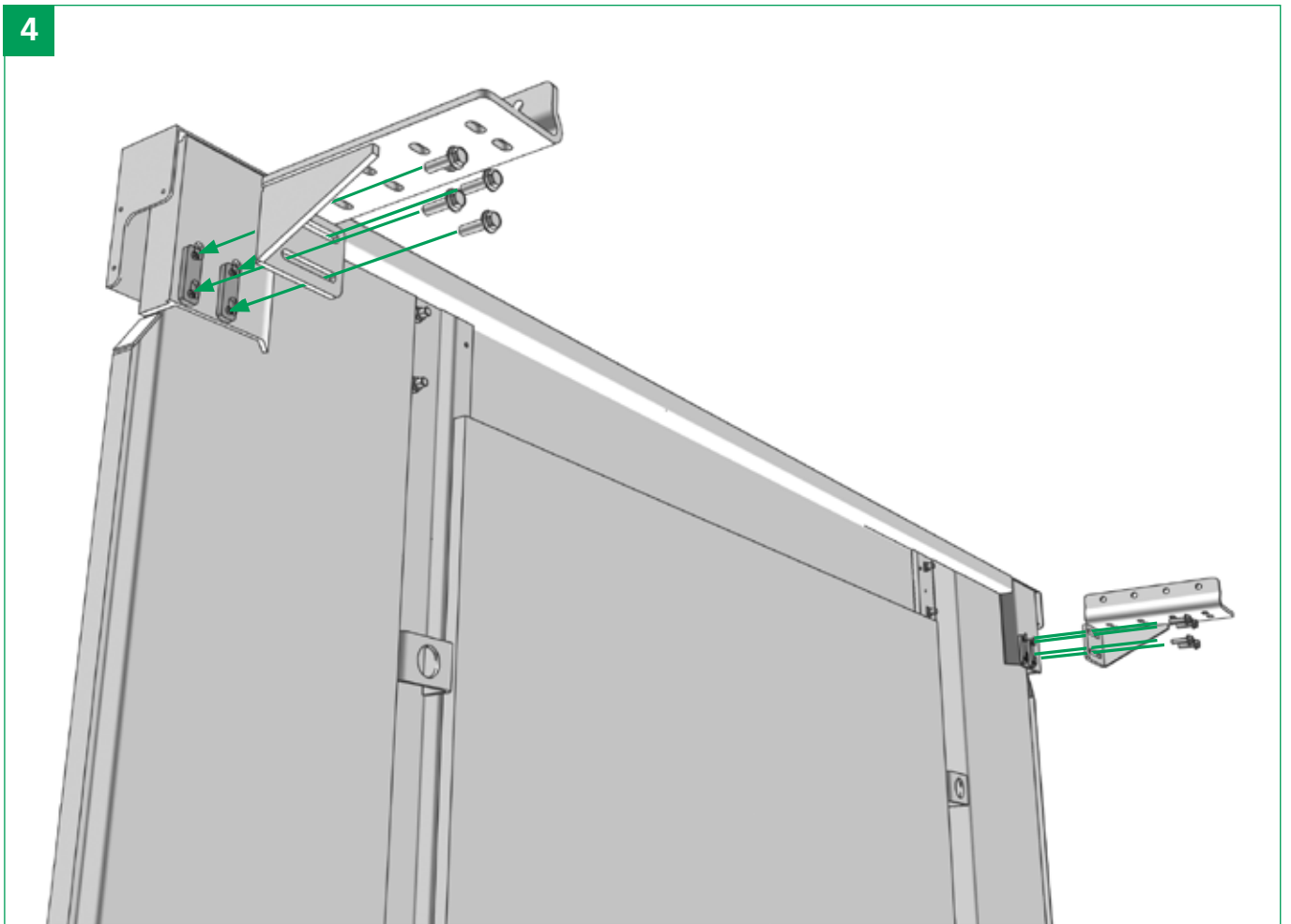

Pre-assemble bulkhead 03

Process step: pre-assemble bulkhead

Process: Mount assembly sets

Parameters: roof track width, guide rail package

Material: Edscha TS Montagesätze

Tools: torque wrench

Aids:

Preparation:

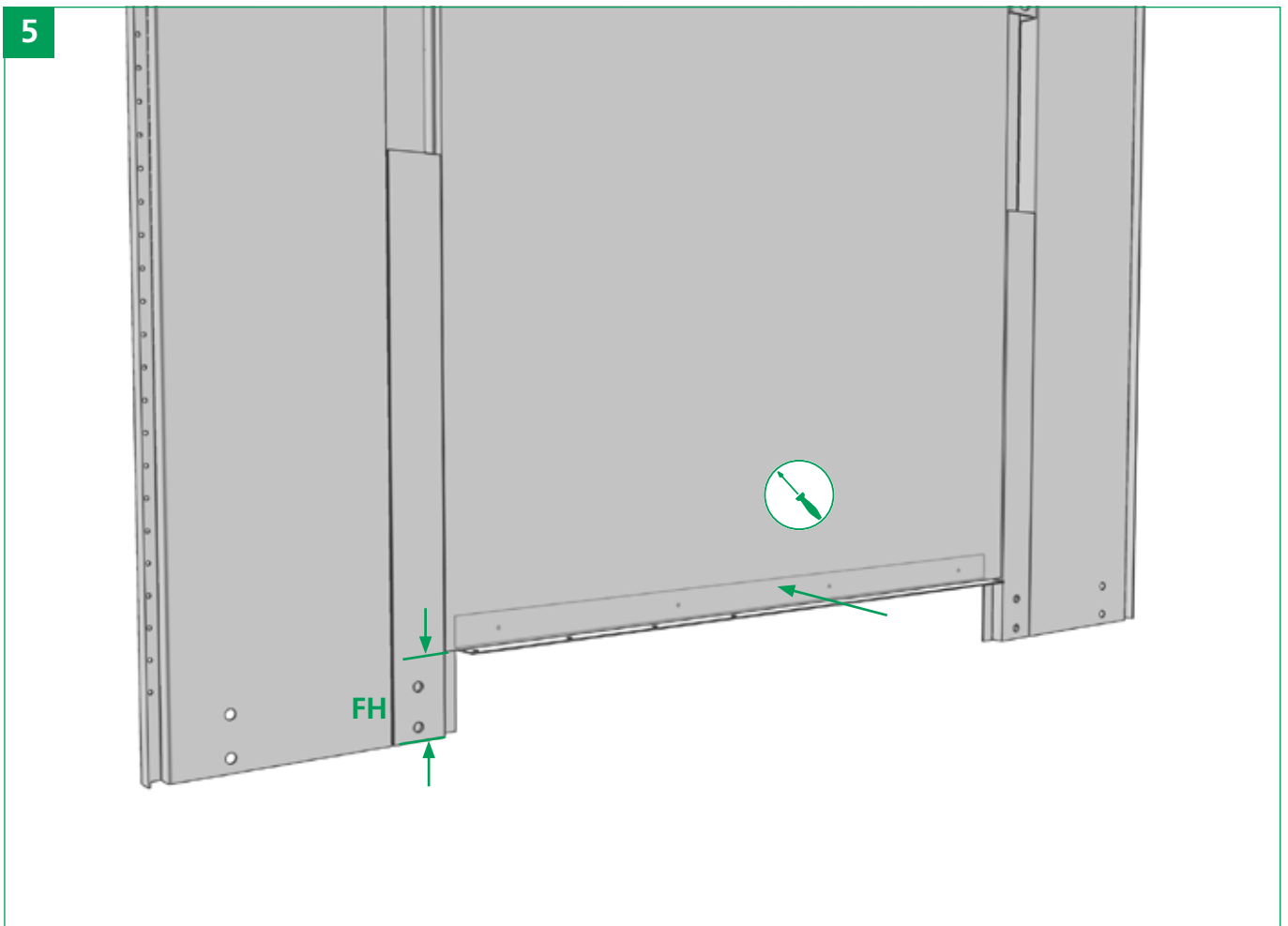

Pre-assemble bulkhead 04

Process step: pre-assemble bulkhead

Process: Mount support angle (adjust if necessary)

Material: Edscha TS support angle, screws

Tools: Screw driver

Aids:

Preparation:

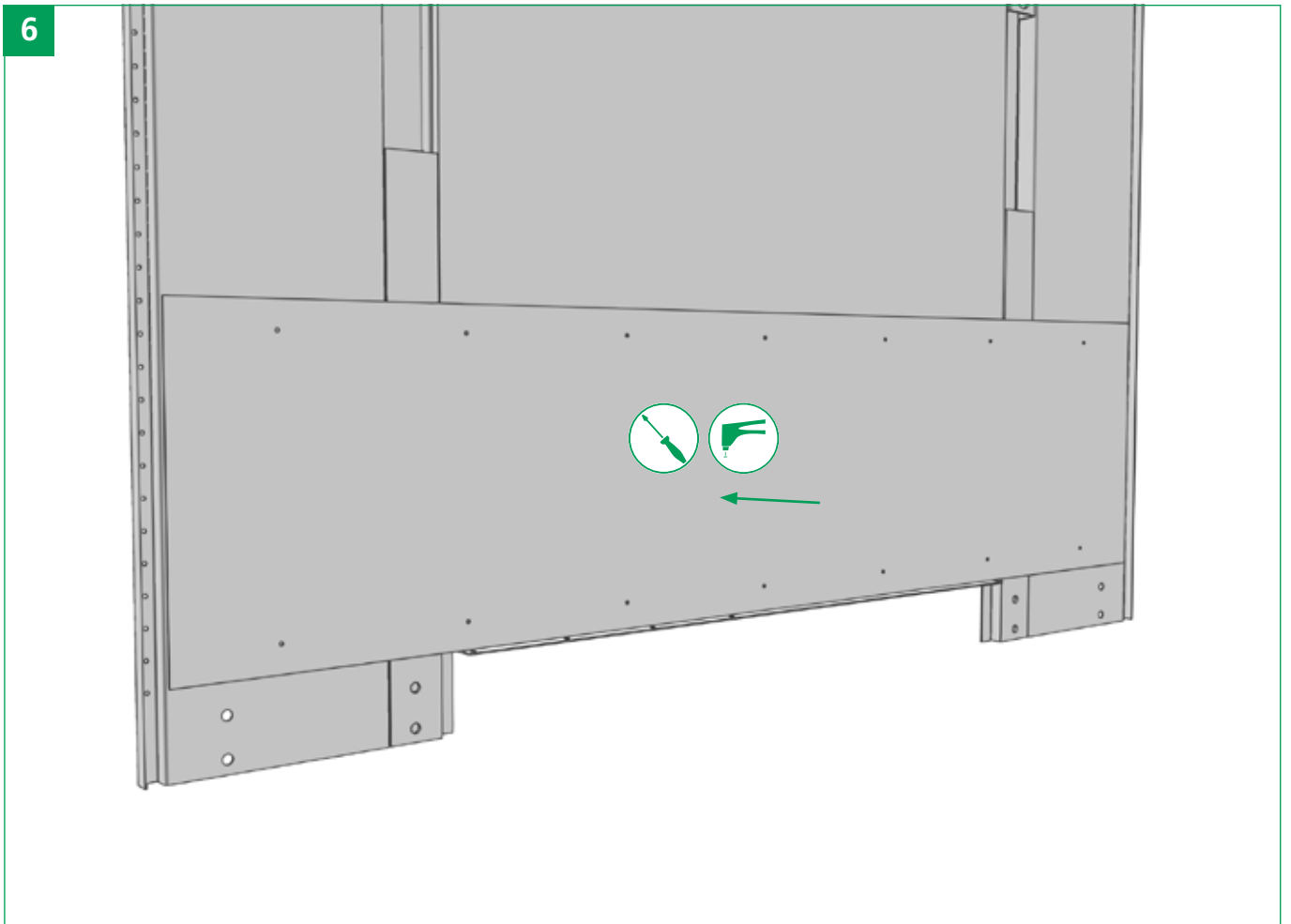

Pre-assemble bulkhead 05

Process step: pre-assemble bulkhead

Process: Mount protective plate (adjust if necessary)

Material: Edscha TS protective plate, screws / rivets

Tools: Riveting pliers / screwdriver

Aids:

Preparation:

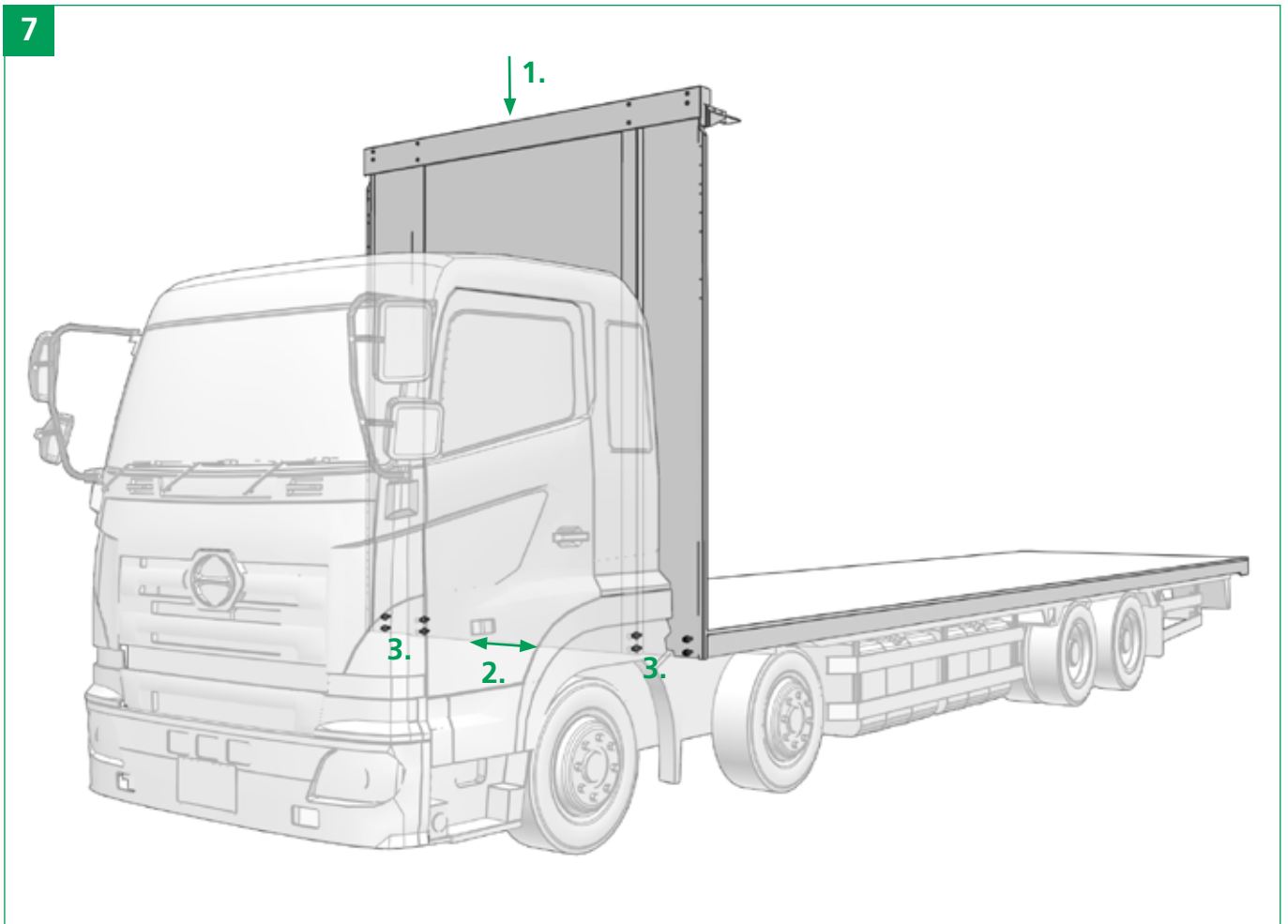

Installing the bulkhead 01

Process step: installing the bulkhead

Process: Align bulkhead and mount

Parameter: Platform width

Material: Pre-mounted Edscha TS bulkhead

Tools: torque wrench, wrench

Aids: crane

Preparation:

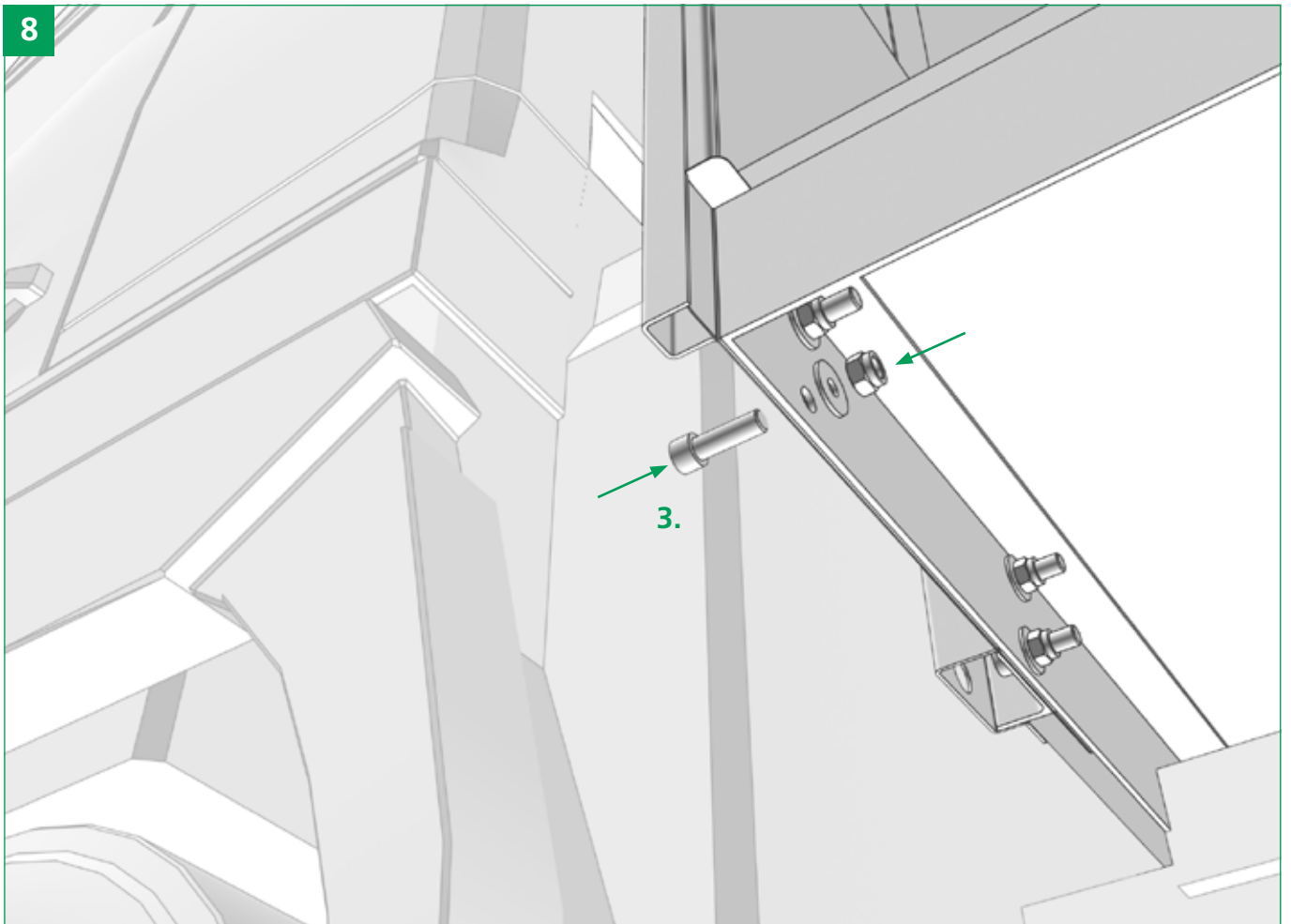

Installing the bulkhead 02

Process step: installing the bulkhead

Process: Screw bulkhead on

Parameter: Torques

Material: pre-assembled Edscha TS bulk head

Tools: torque wrench, wrench

Aids:

Preparation:

9

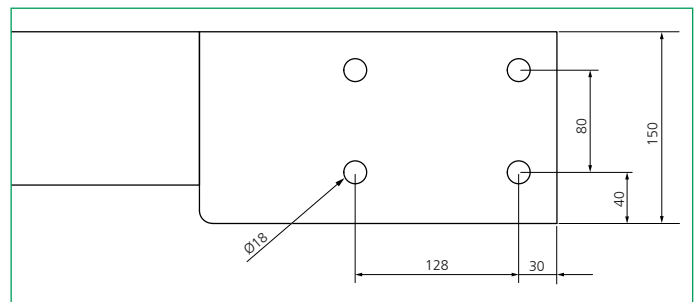
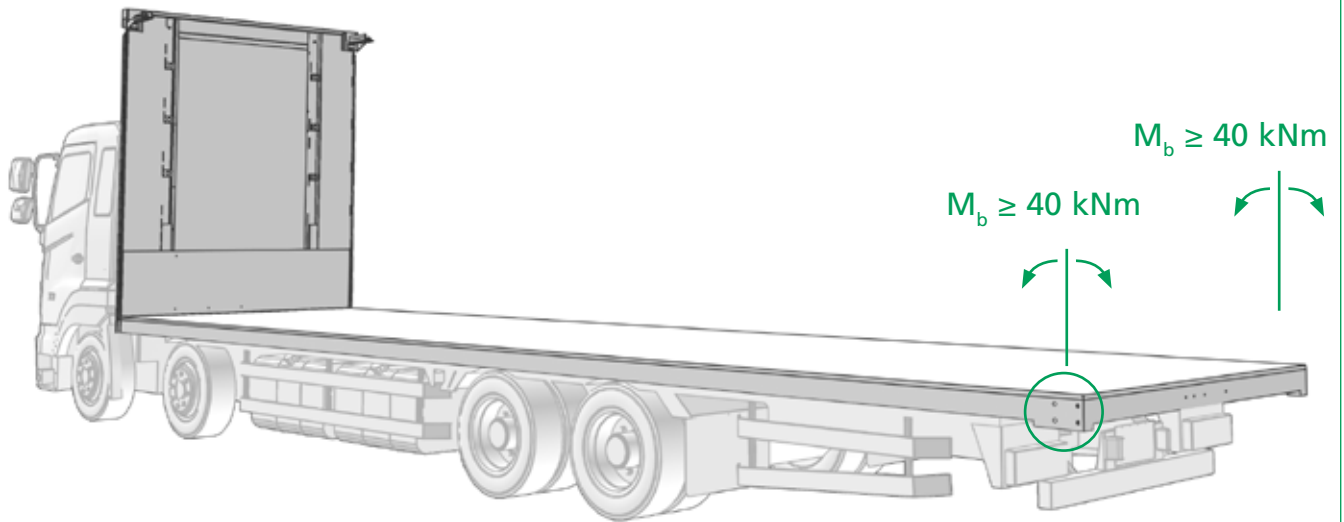

Preparing the rear 01

Process step: preparing the rear

Process: Drill holes for rear frame

Parameters: Platform width, requirements PWP SA

Material:

Tools: measurement/marketing tools, drilling machine

Aids:

Preparation:

10

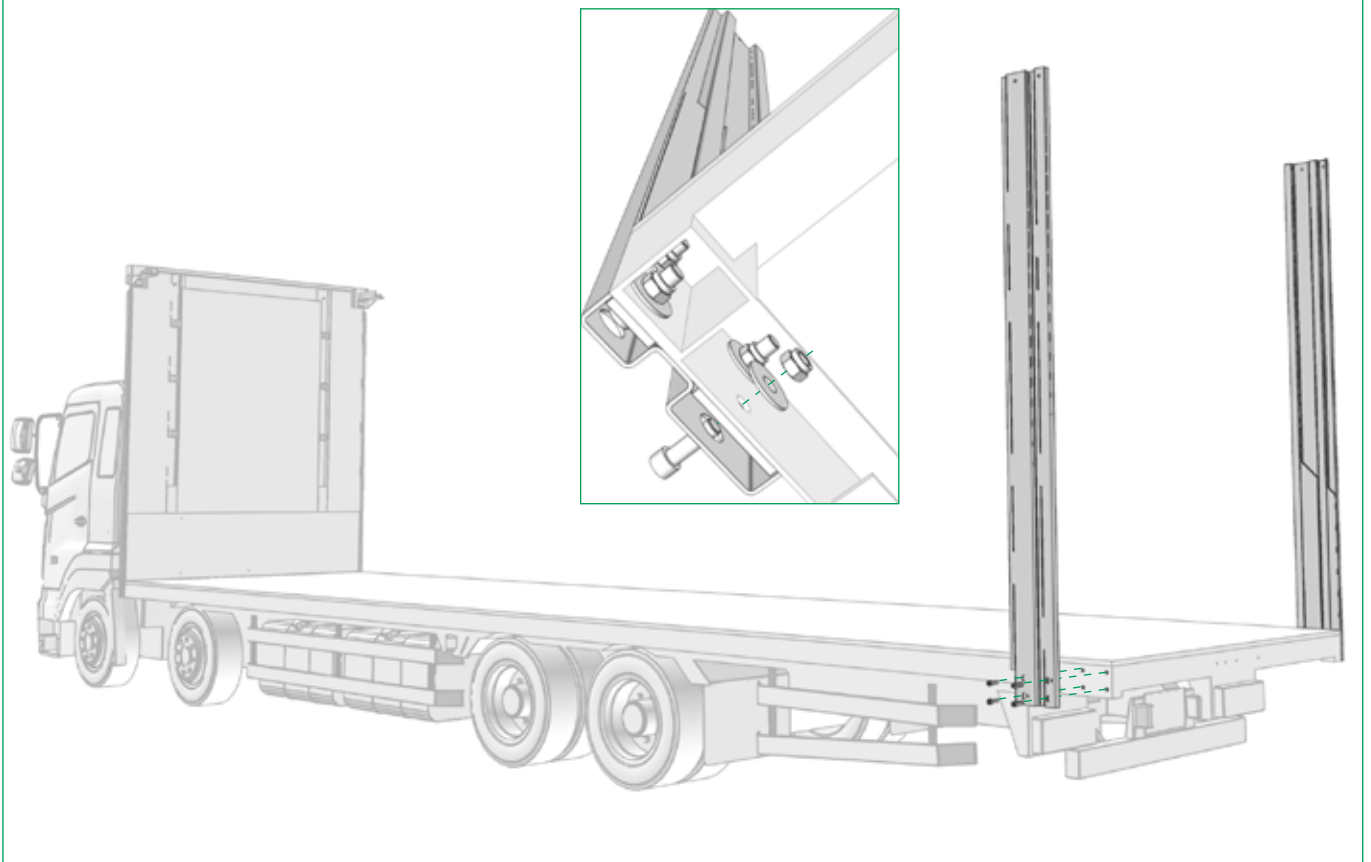

Preparing the rear 02

Process step: preparing the rear

Process: Screws on rear pillars

Parameters: Platform width, requirements PWP SA

Material: Edscha TS rear pillars 2102, attachment materials

Tools: wrench, torque wrench

Aids:

Preparation:

11

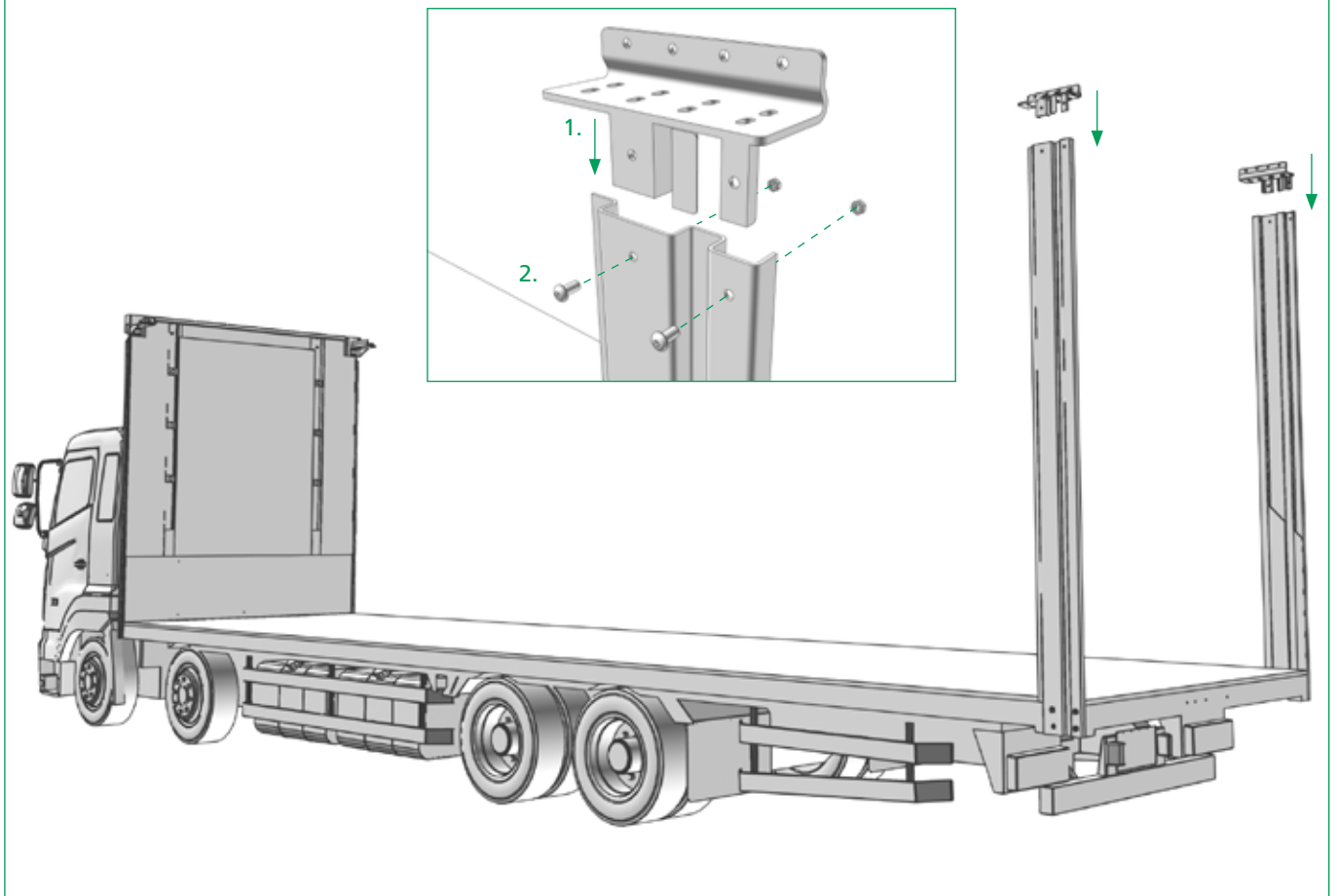

Preparing the rear 03

Process step: preparing the rear

Process: Mount assembly sets

Parameters: roof track width, guide rail package

Material: Edscha TS assembly sets, attachment material

Tools: wrench, torque wrench

Aids:

Preparation:

12

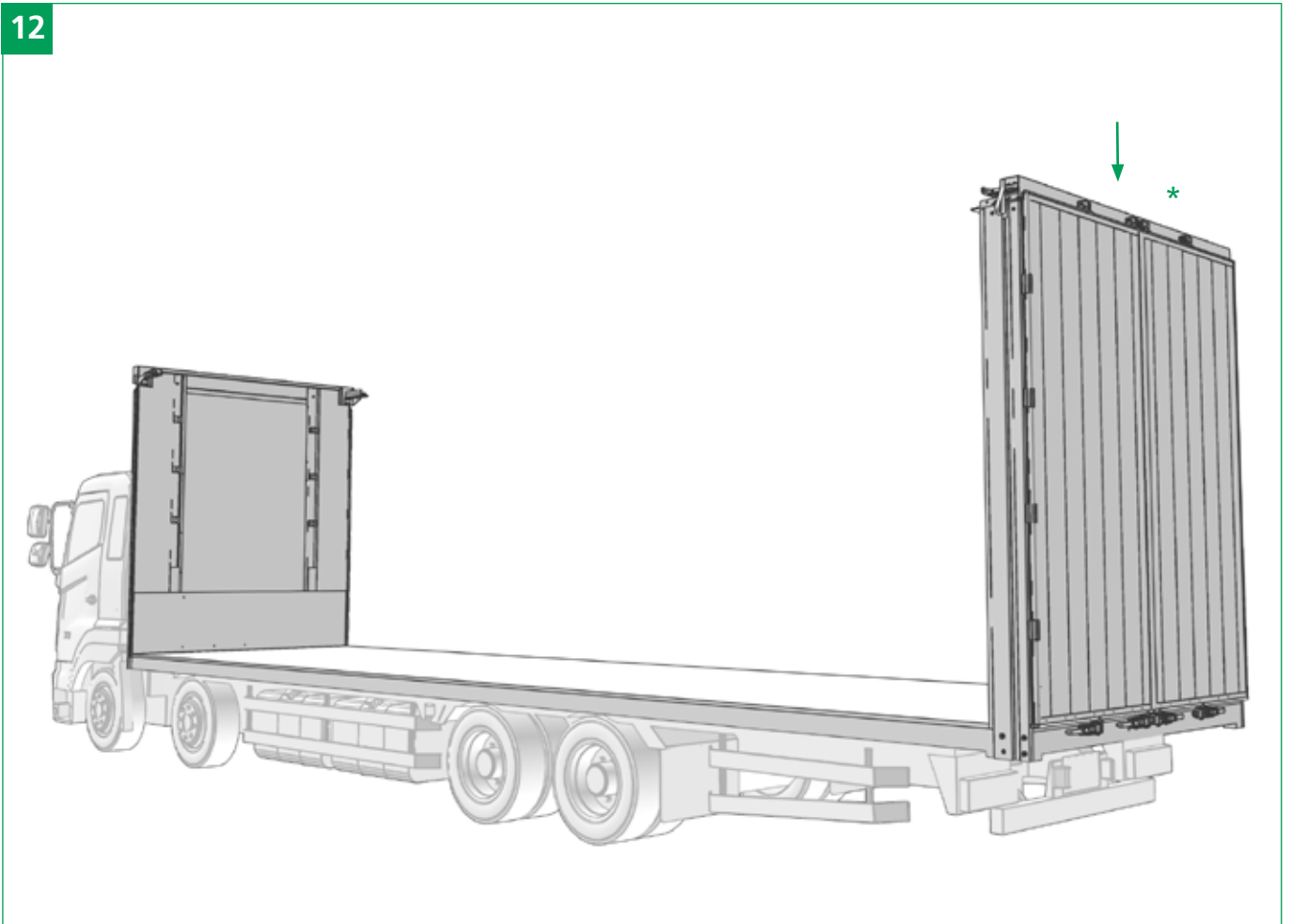

Rear doors (PWP SA)

Process step: installation rear frame / rear doors

Process: installation rear frame / rear doors

Parameters: Platform width, installation height, requirements PWP SA

Material: Edscha TS rear frame (2102)

Tools: torque wrench, wrench

Aids: crane

Preparation: See assembly instructions PWP Defender

Assembly instructions PWP Defender:

<http://bit.ly/29gZDjr> (Sandwich)

<http://bit.ly/29qllzM> (Snaplock)

13

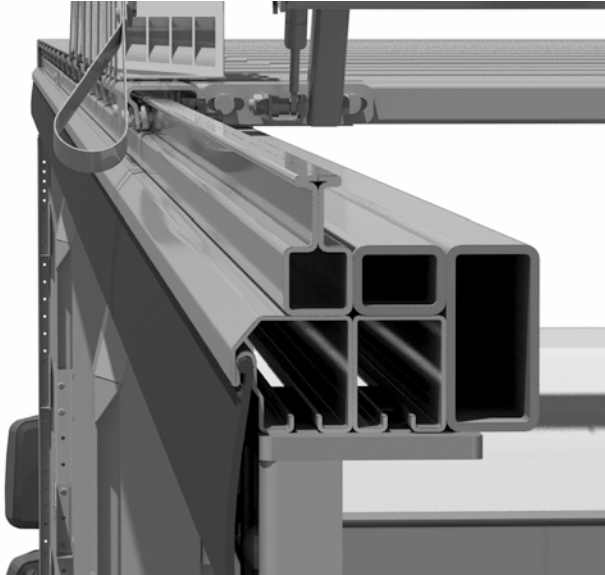

Sliding pillar

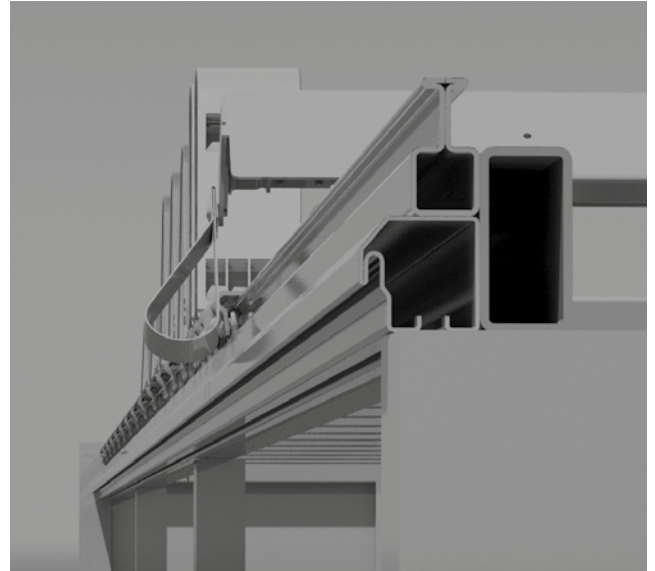

Fixed pillar

Guide rails

Process step: mount guide rails

14

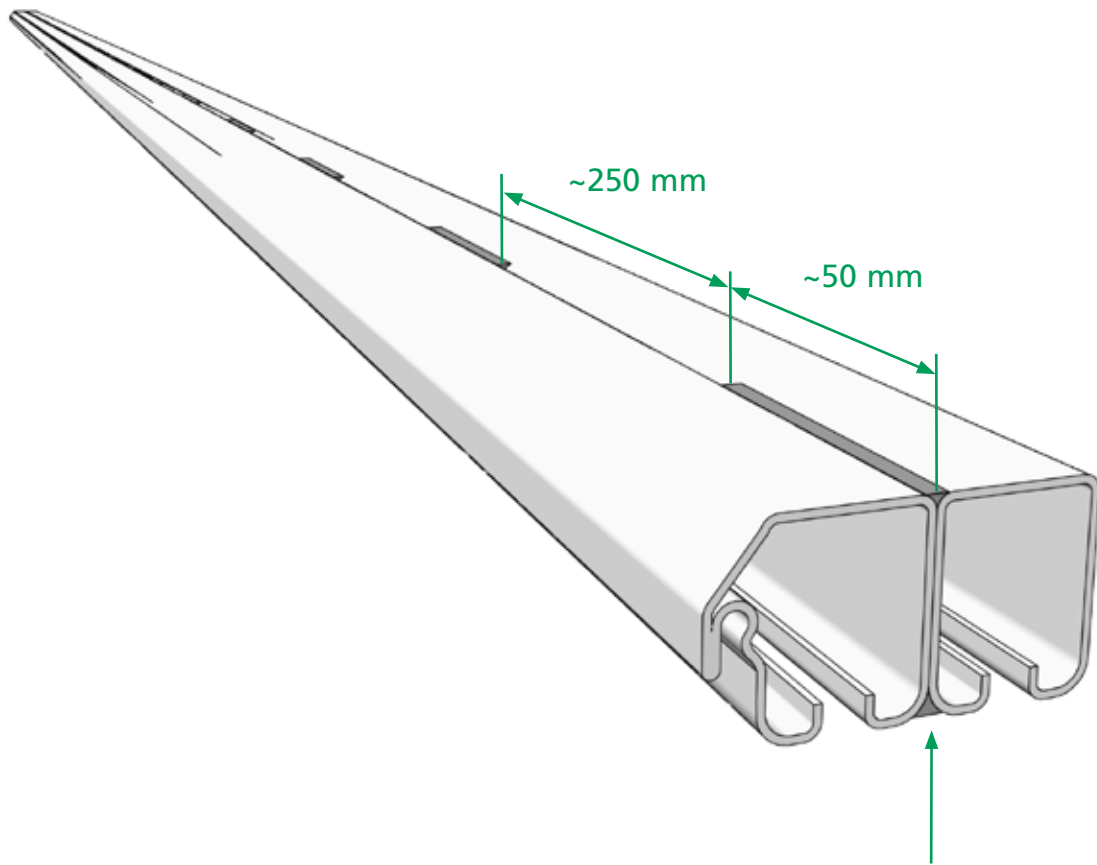

Guide rail package 01

Weld CurtainSider profile and sliding pillar profile (top)

15

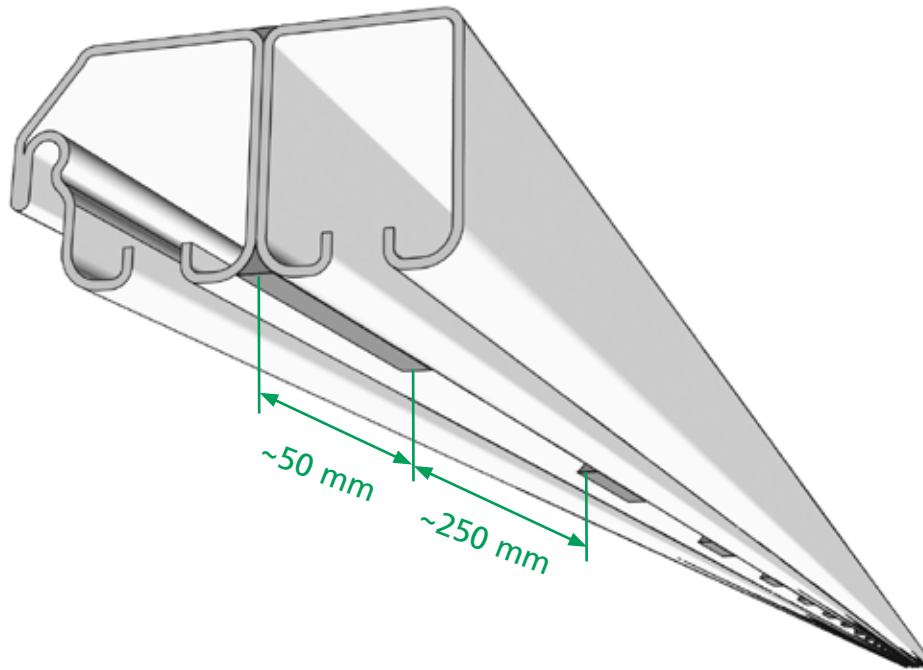

Guide rail package 02

Weld CurtainSider profile and sliding pillar profile (base)

16

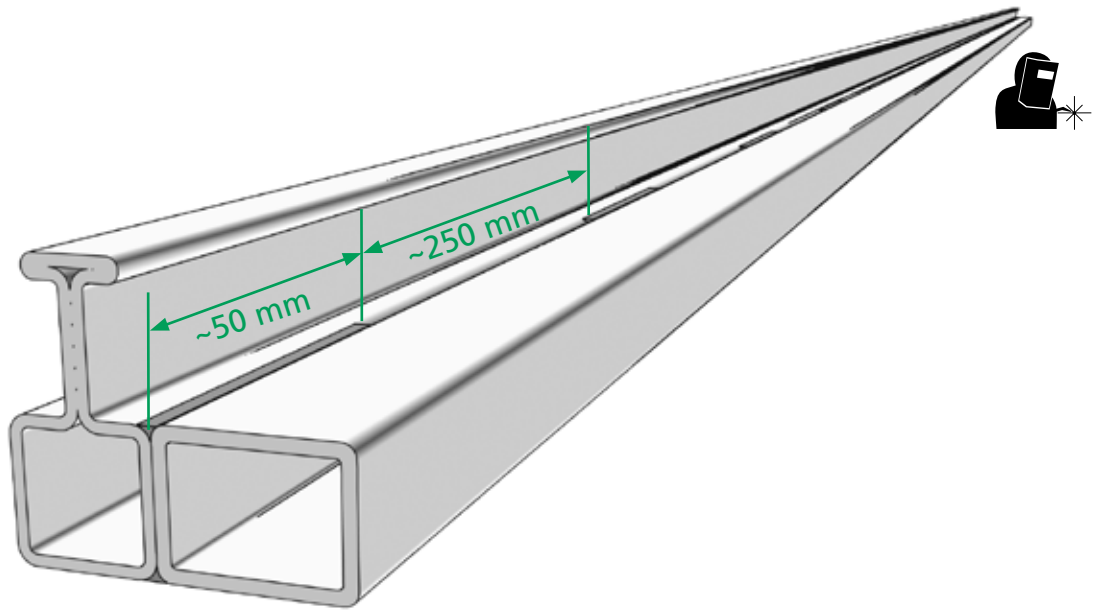

See page 38 and consecutive pages

Guide rail package 03

Weld running rail and rectangular tube (top)

17

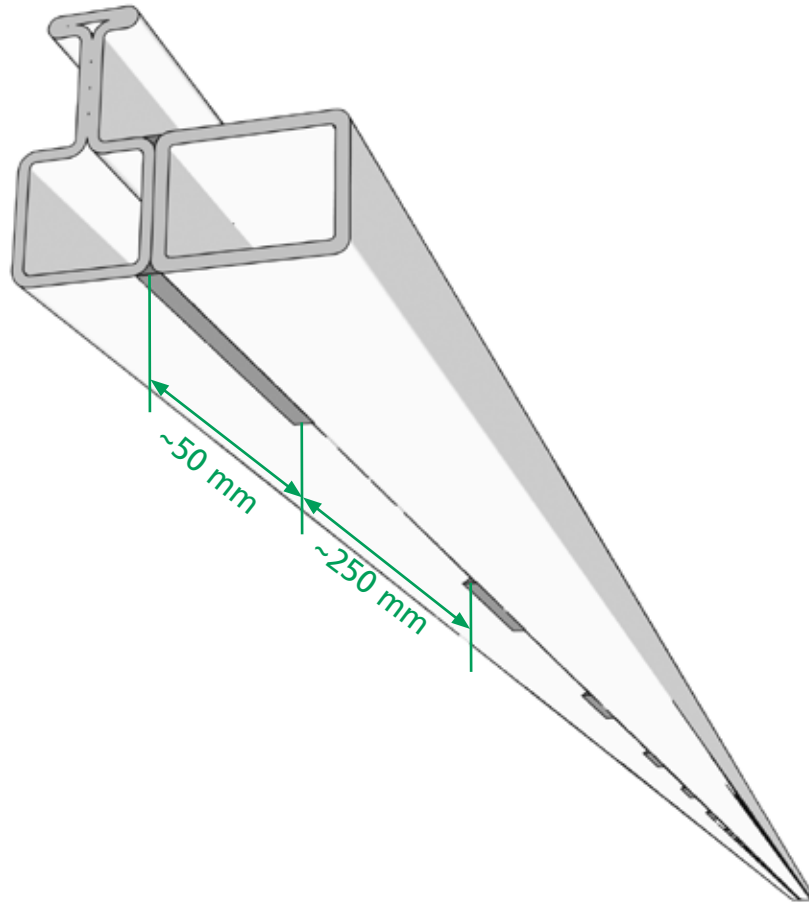

Guide rail package 04

Weld running rail and rectangular tube
(base)

18

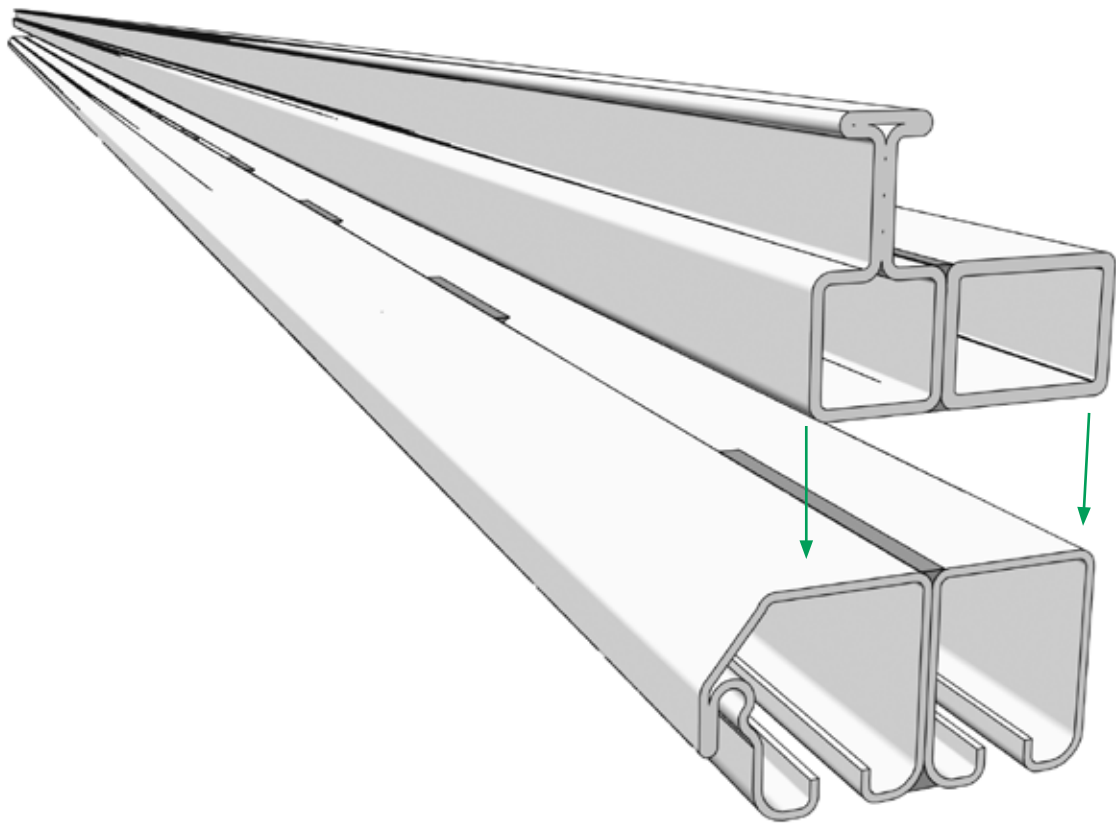

Guide rail package 05

Join welded profile packages

19

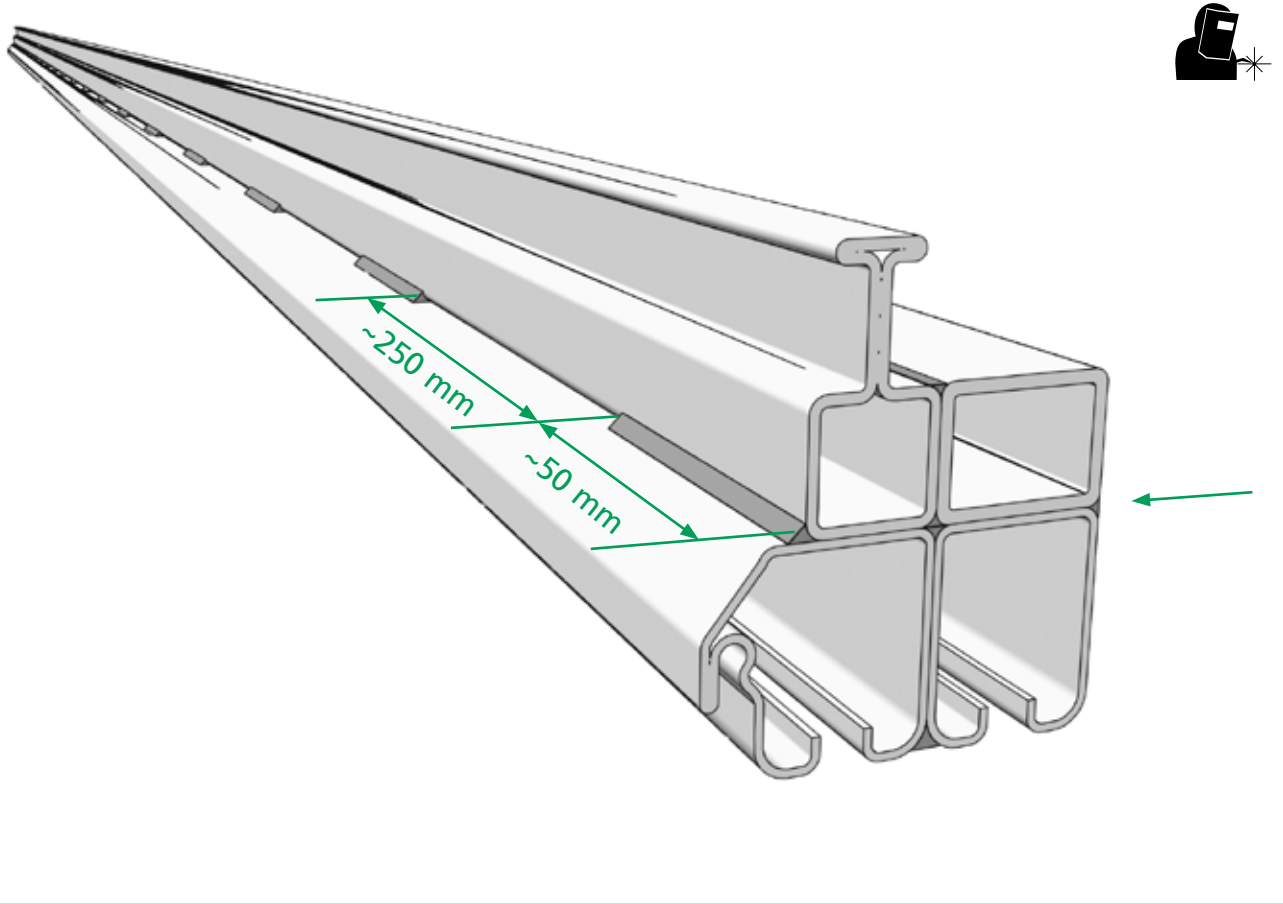

Guide rail package 06

Weld profile packages
(outside)

20

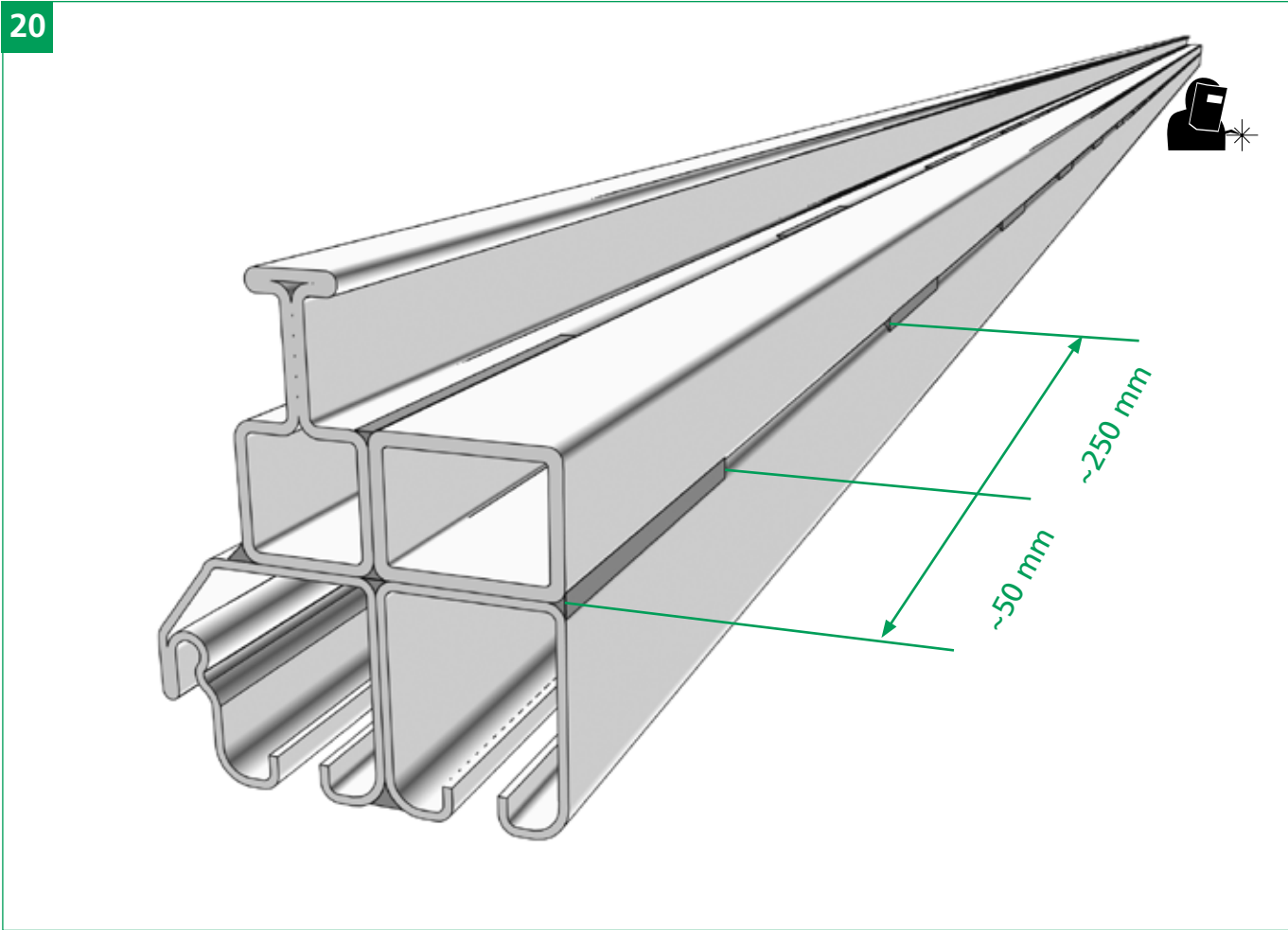

Guide rail package 07

Weld profile packages
(inside)

21

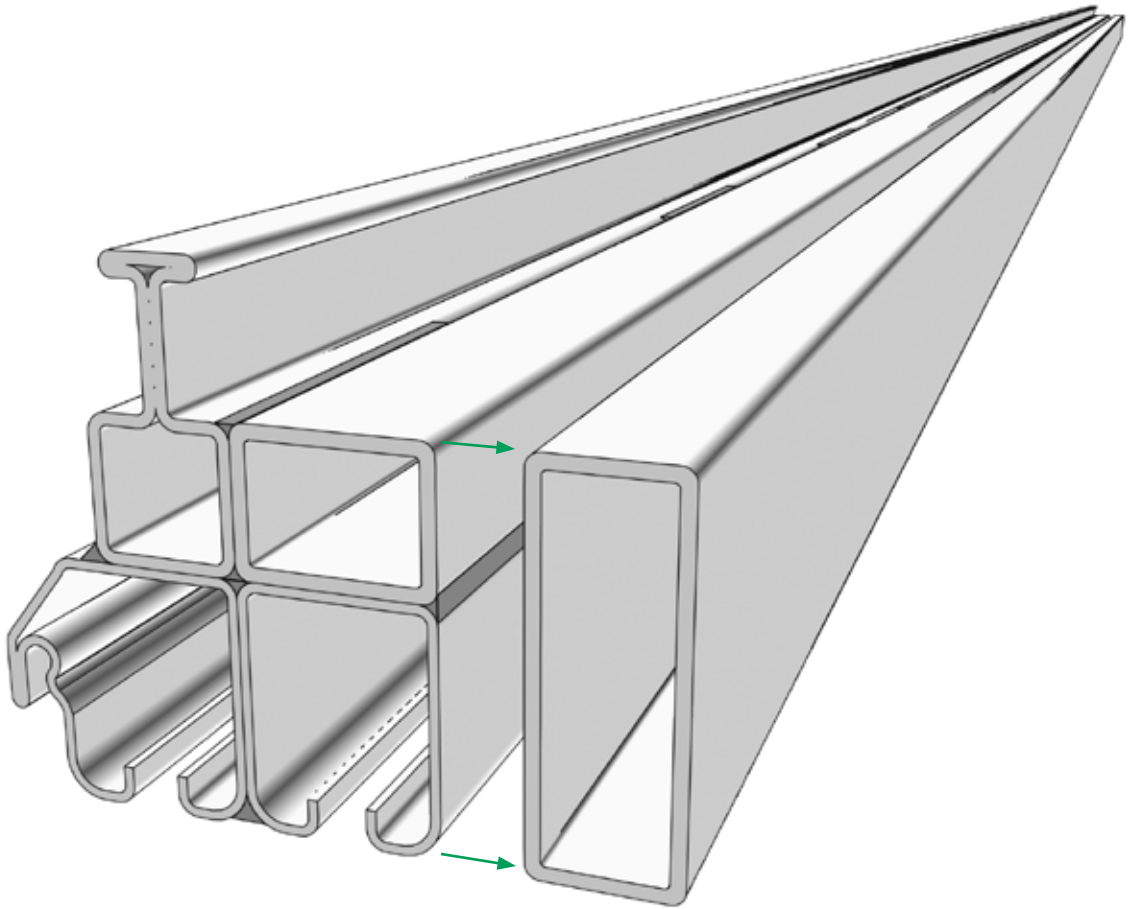

Guide rail package 08

Join welded profile package with stabilisation tube

22

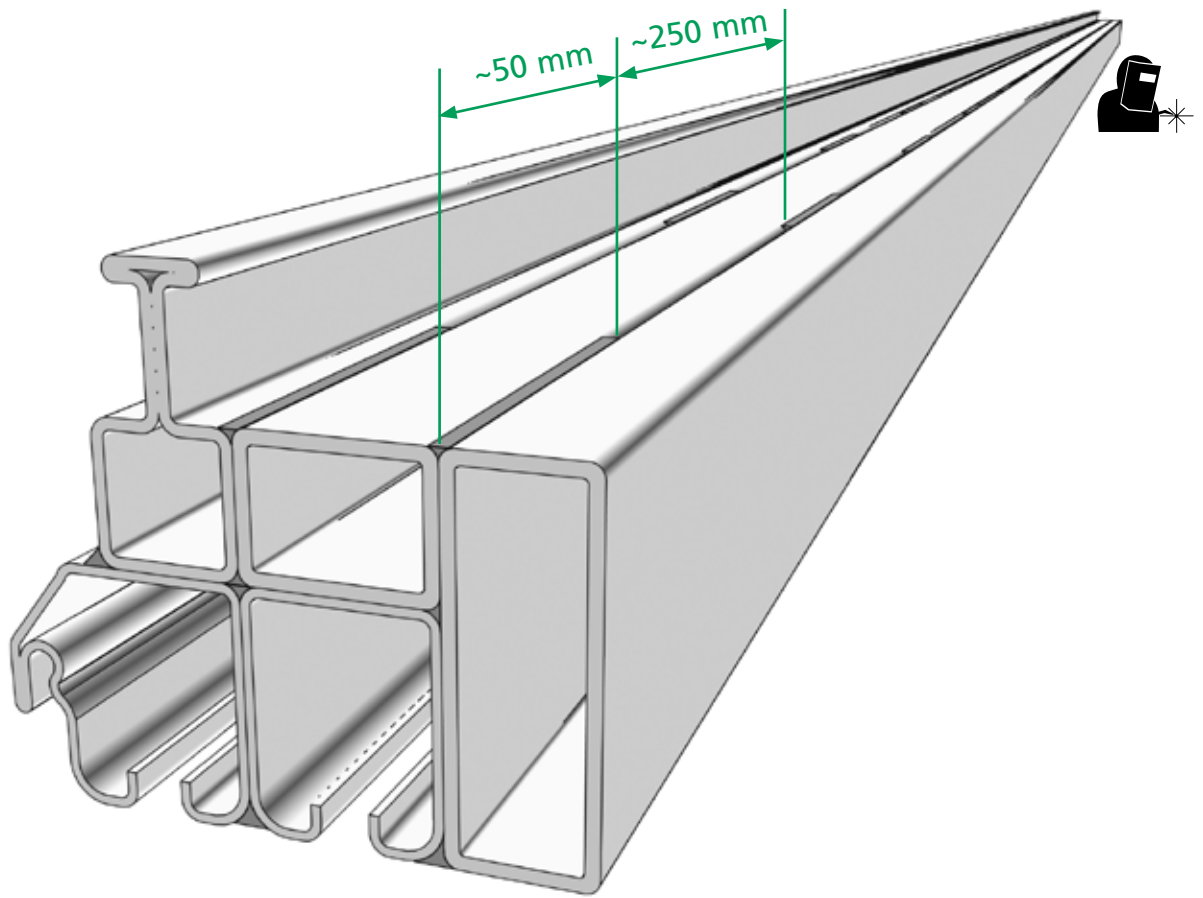

Guide rail package 09

Weld profile package (with a high profile weight or long self-supporting lengths the profiles may need to be welded with preload, **see following illustrations**)

23

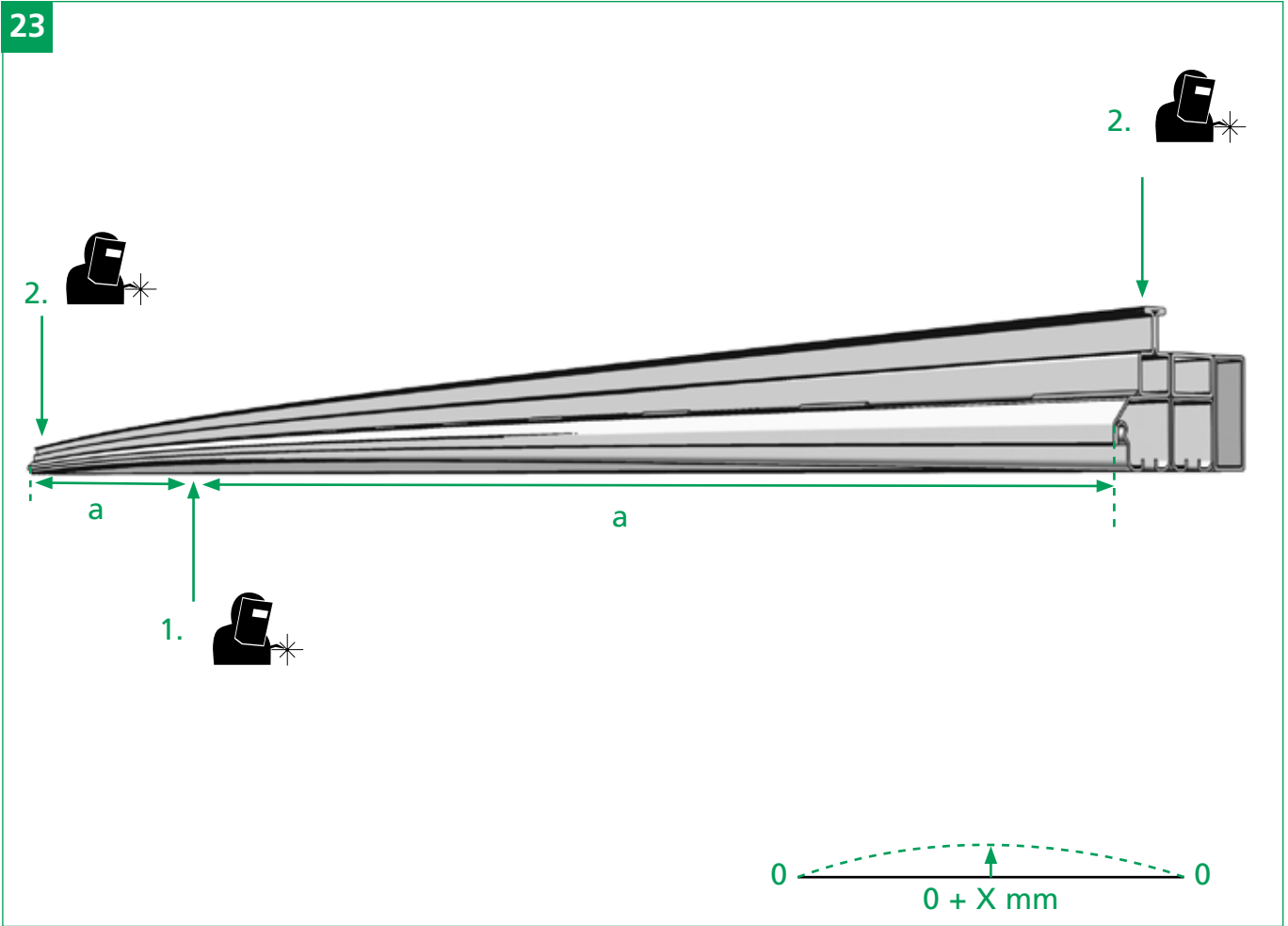

Guide rail package 10

Weld profile package with preload.
 Compensate profile deflection through counterload on profile.

24

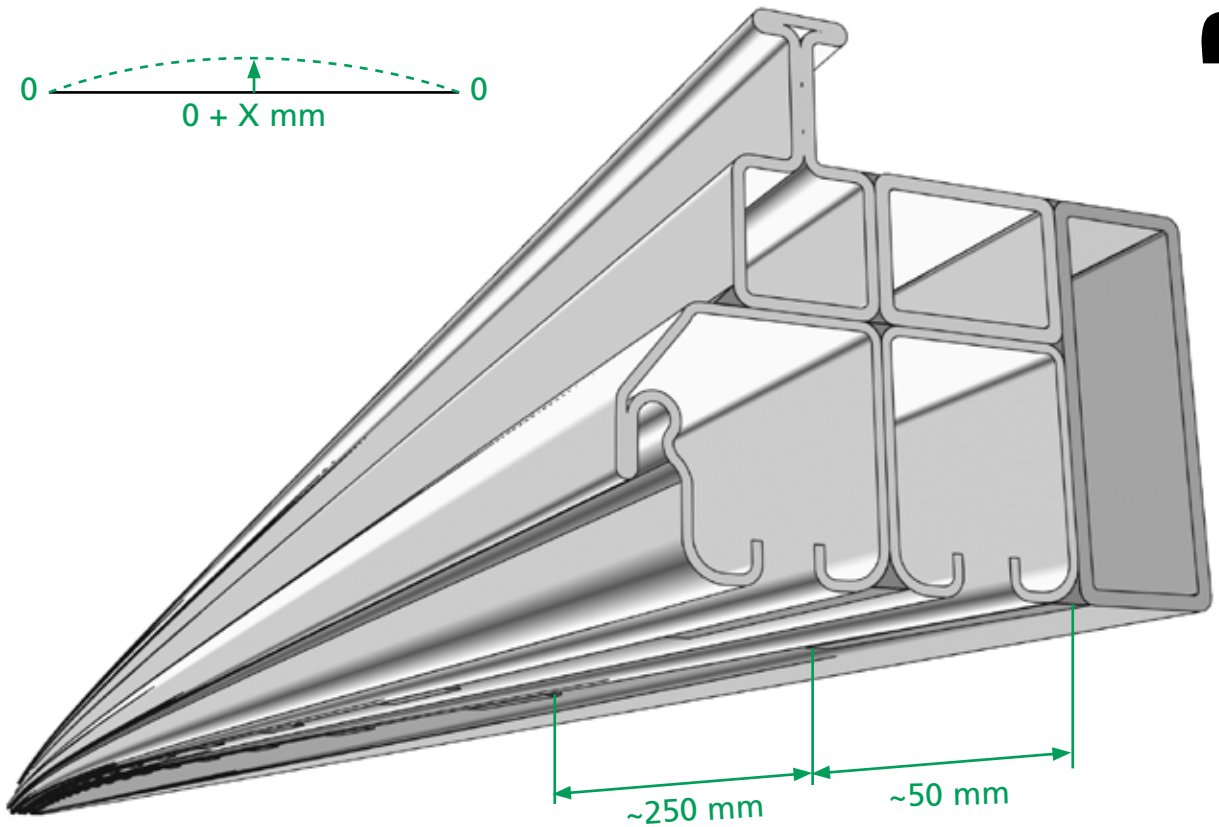

Guide rail package 11

Join welded profile packages
(base)

25

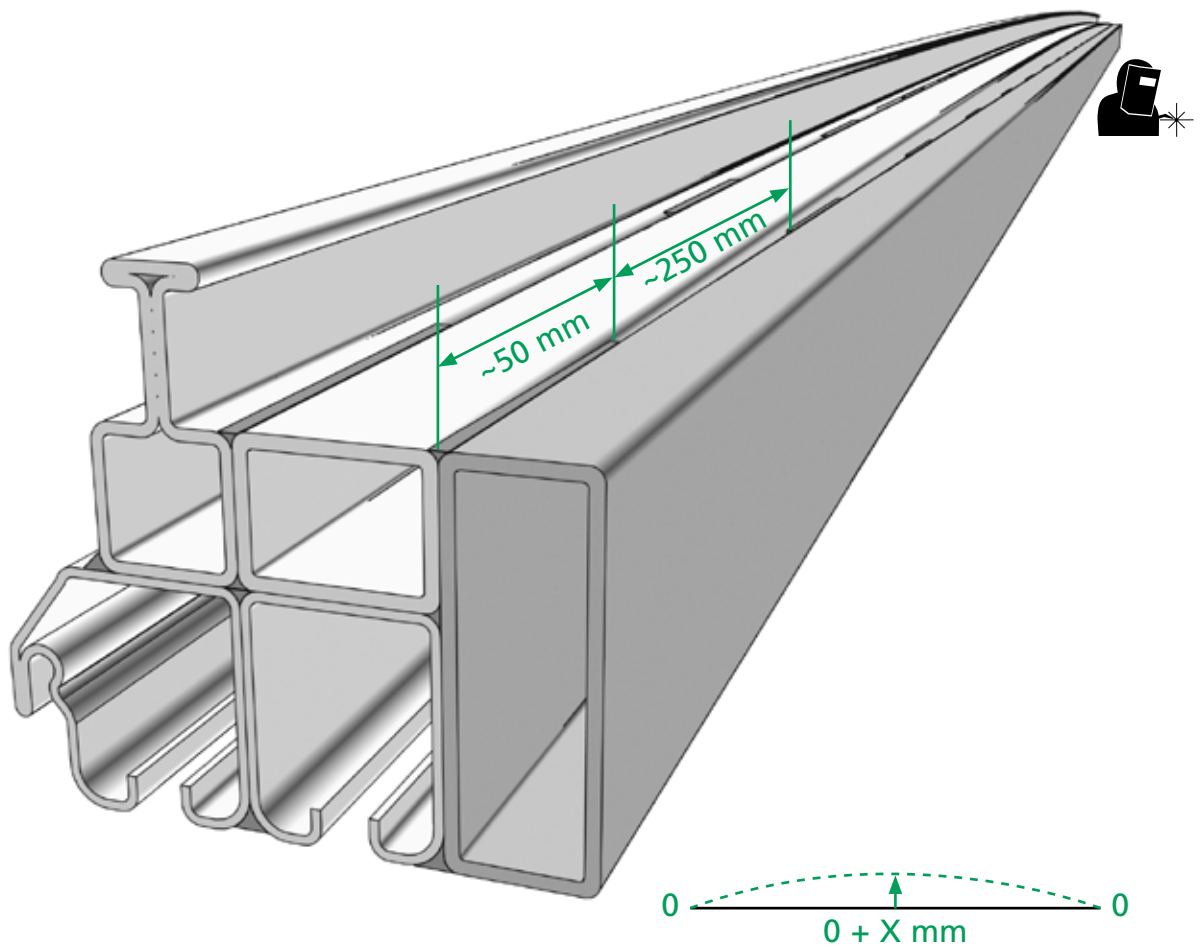

Guide rail package 12

Join welded profile packages
(top)

26

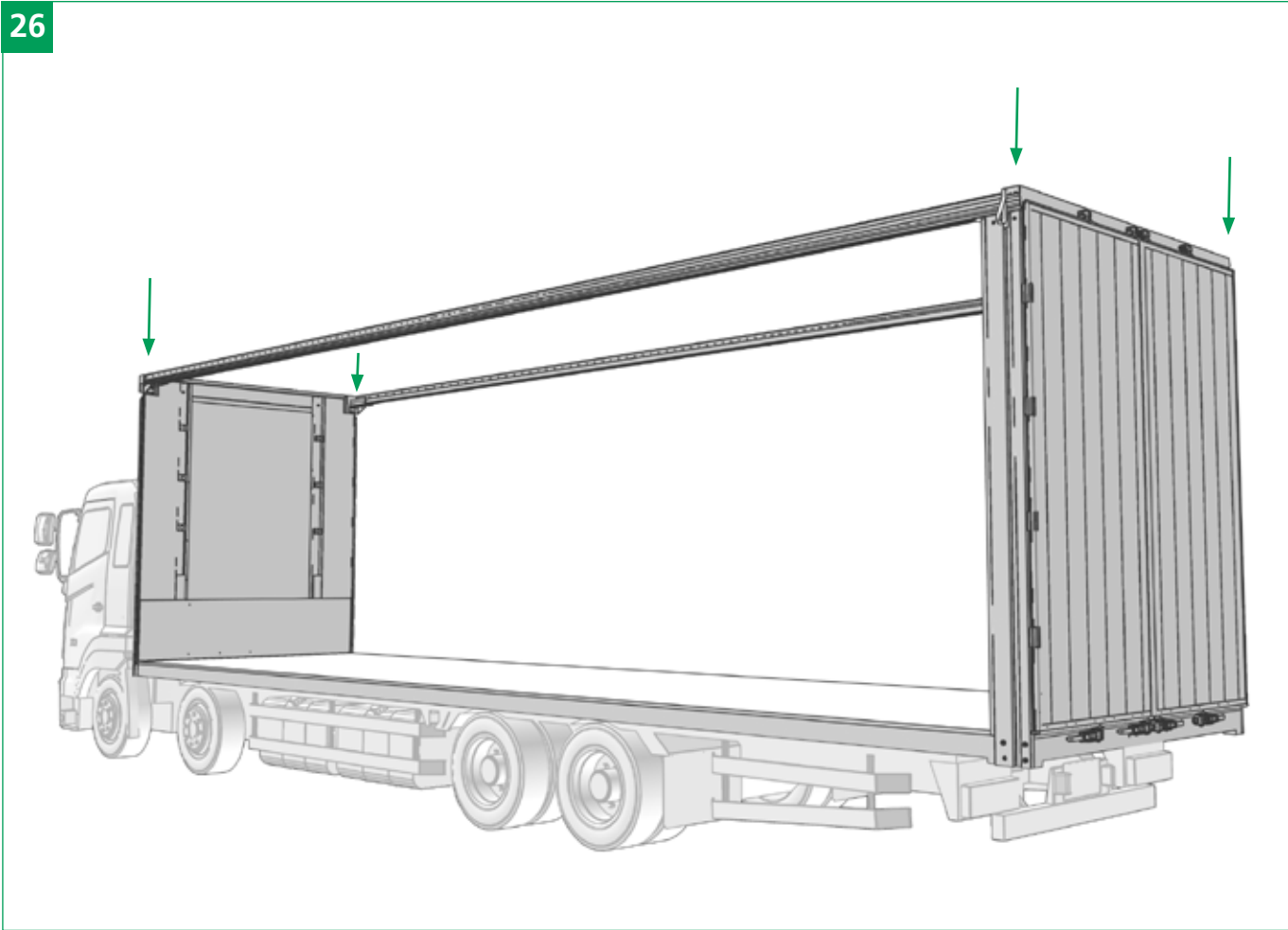

Installing the guide rails

27

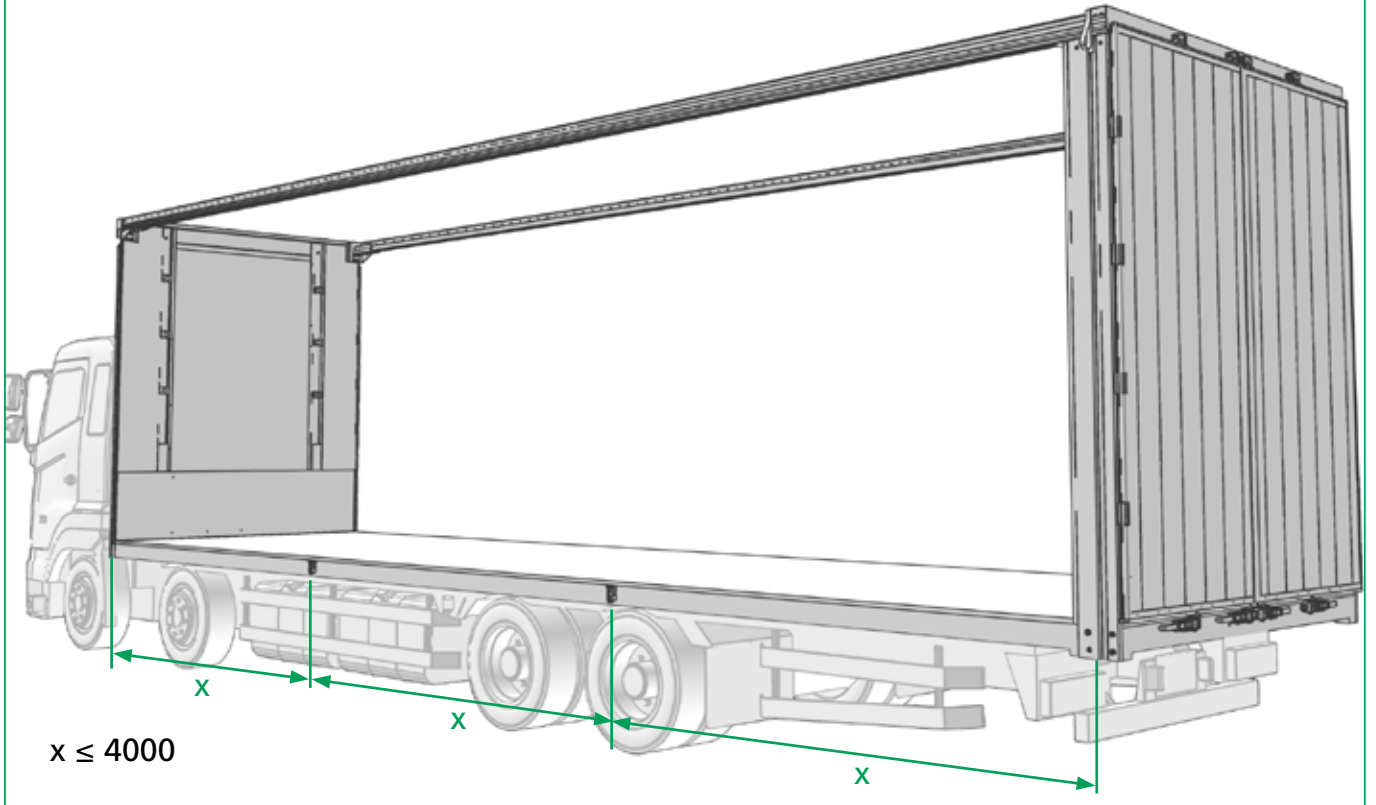

Installing pillar bases 01

Process step: installing pillar bases

Process: installing pillar bases

Parameters: Installation length

Material: Edscha TS pillar bases (LP2)

Tools: measurement/marketing tools

Aids:

Preparation:

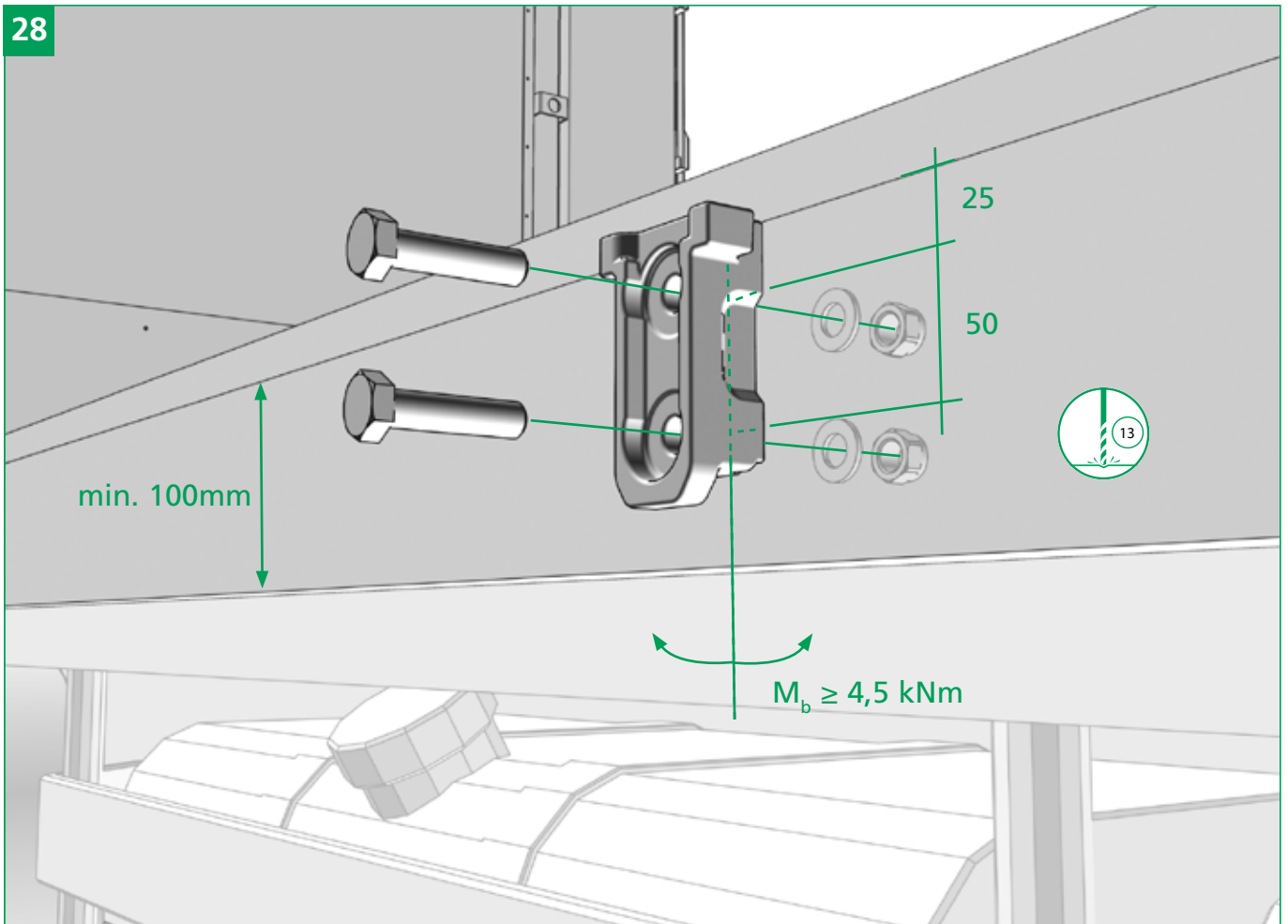

Installing pillar bases 02

Process step: installing pillar bases

Process: installing pillar bases

Parameters: Platform height

Material: Edscha TS pillar bases (LP2)

Tools: measurement/marketing tools, drilling machine

Aids:

Preparation:

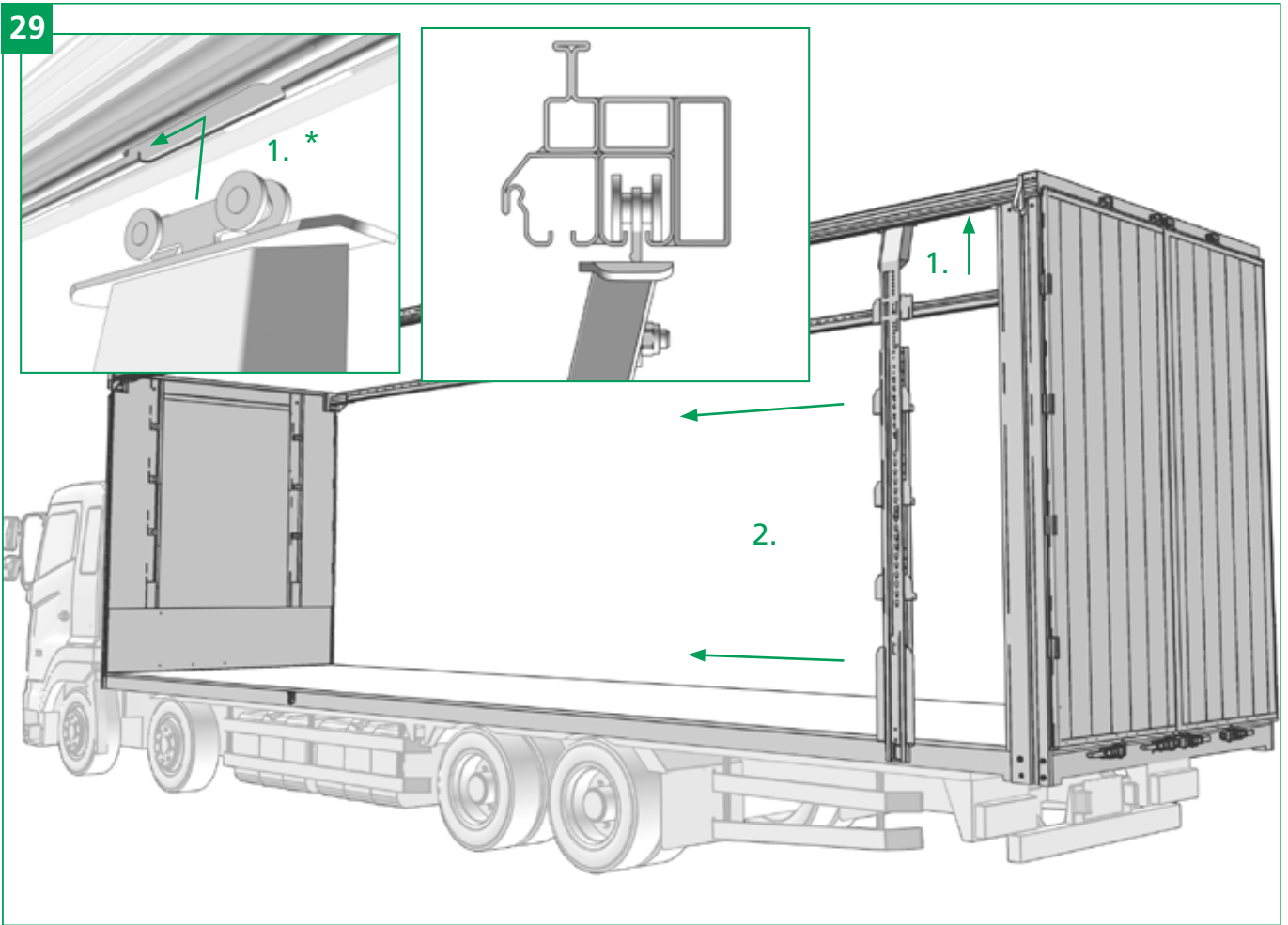

Inserting sliding pillars

*Notch to be performed by customer

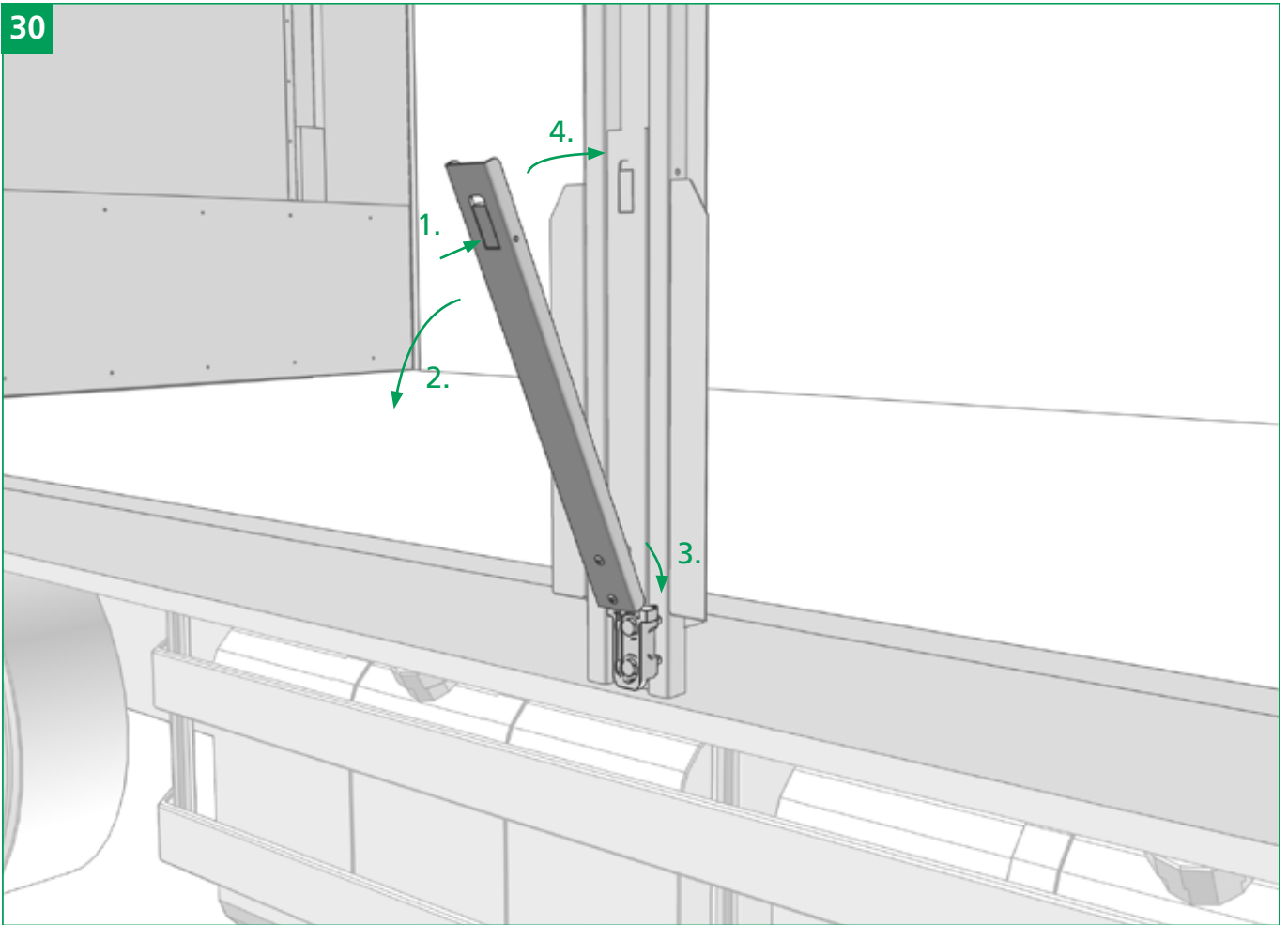

Hook in sliding pillars

31

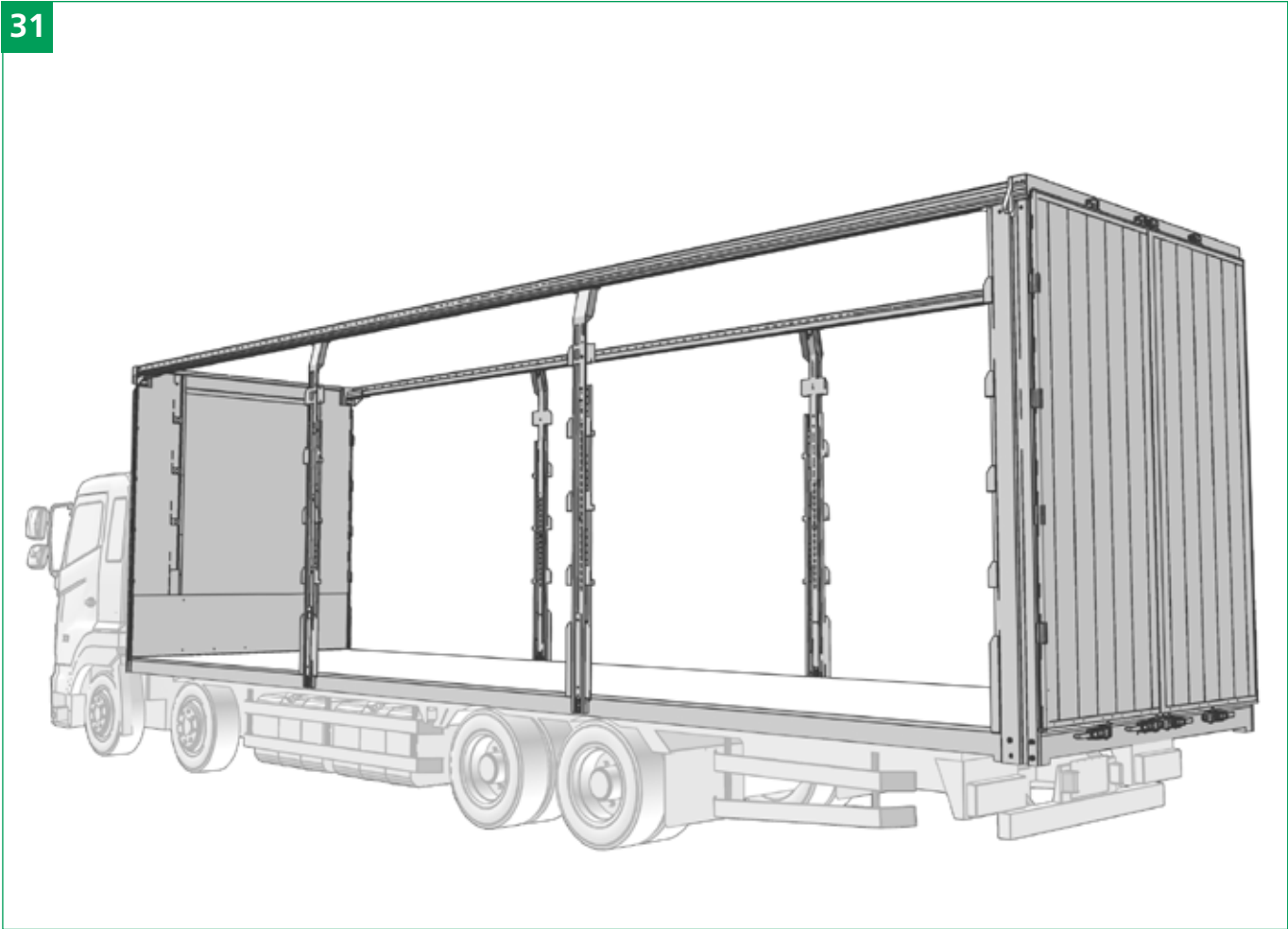

Installing batten pockets

32

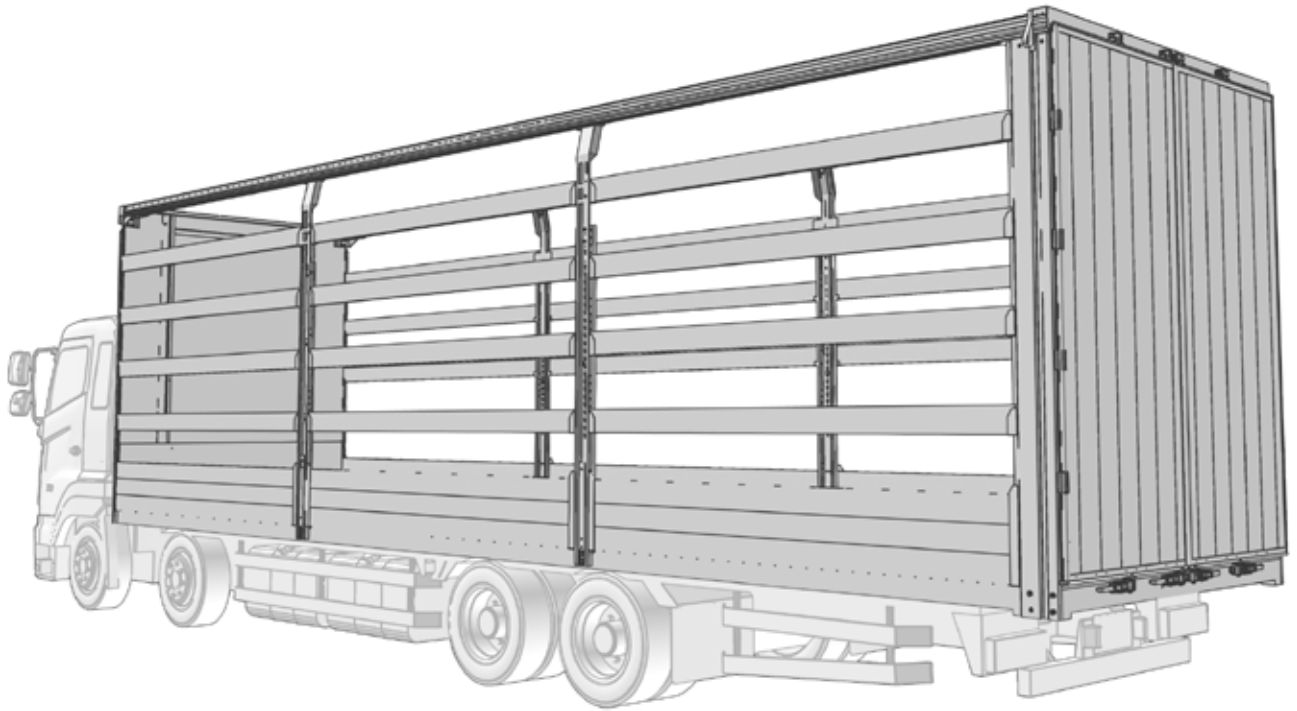

Installing battens

33

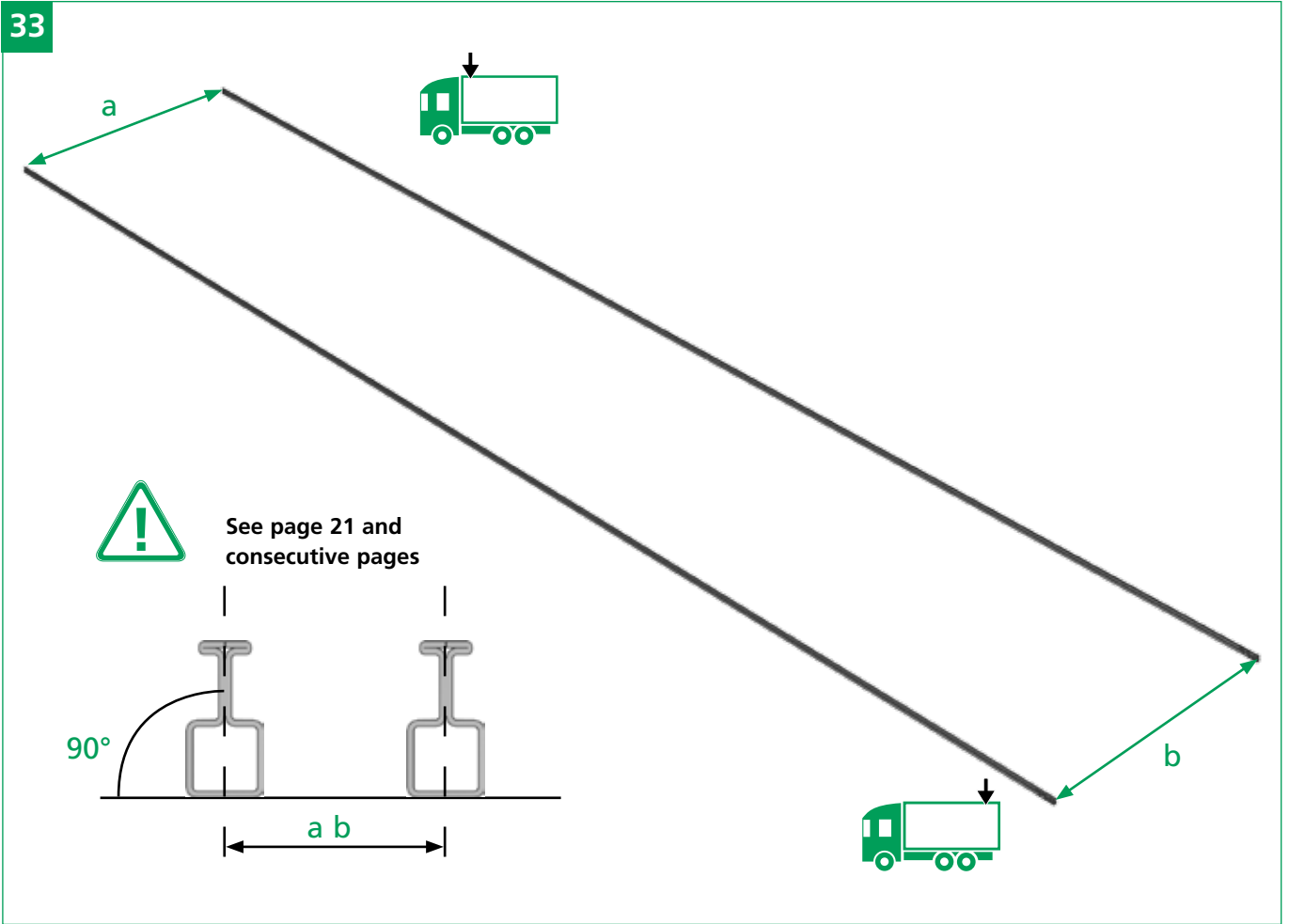

Guide rails

The rails must be mounted in parallel within a maximum angle deviation of $\pm 1^\circ$ and must be braced against rotation at the same height in order to ensure perfect roof running.

Measurement a b -> see figure 48

34

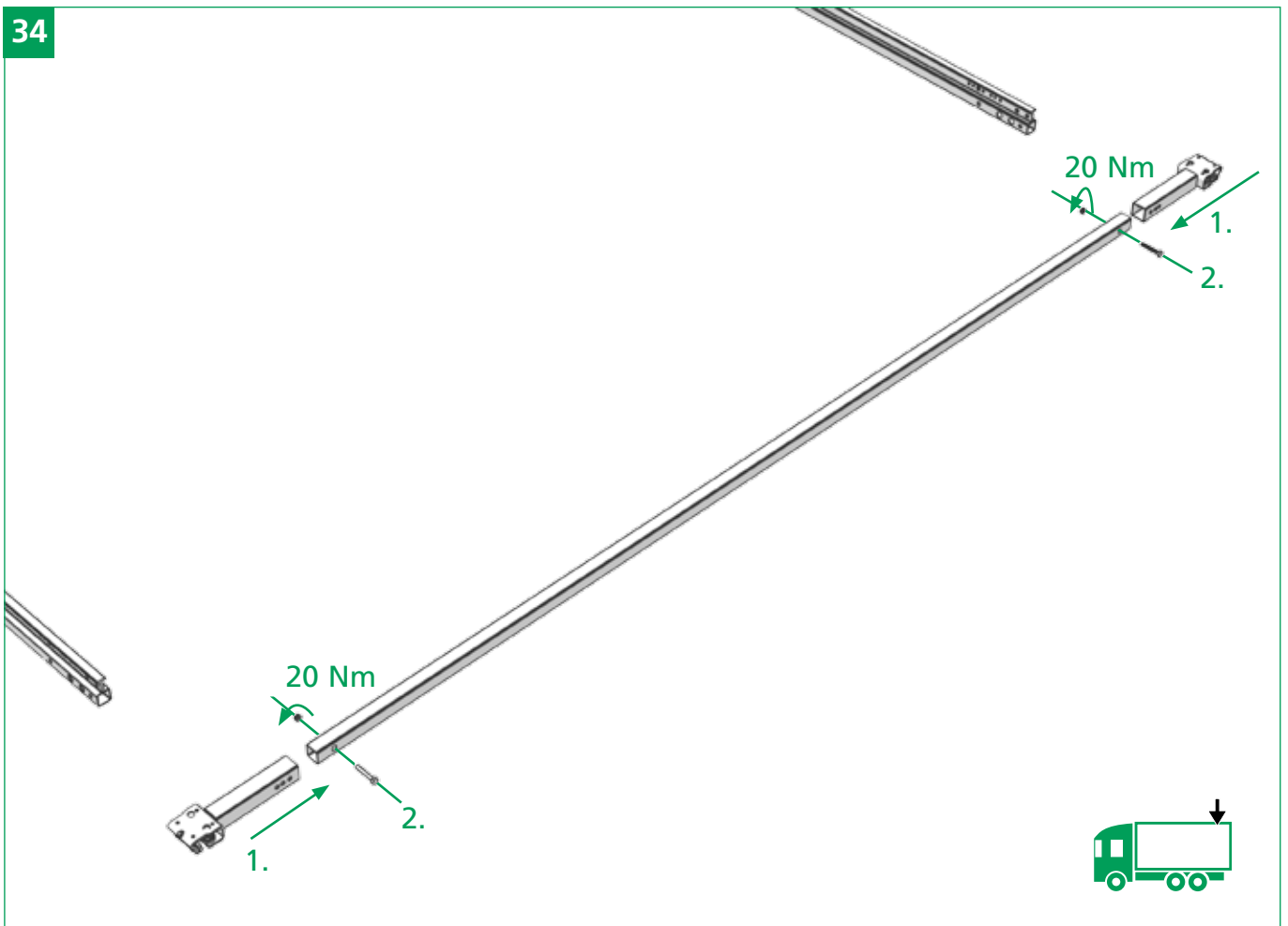

Preassemble bows

Push the bow bracket (right / left) onto the bow from the outside until the provided mounting holes align. Fasten the bulkhead bow bracket to the bow on both sides, using the pan head screw M8x50 and locknut M8 (torque: 20 Nm)

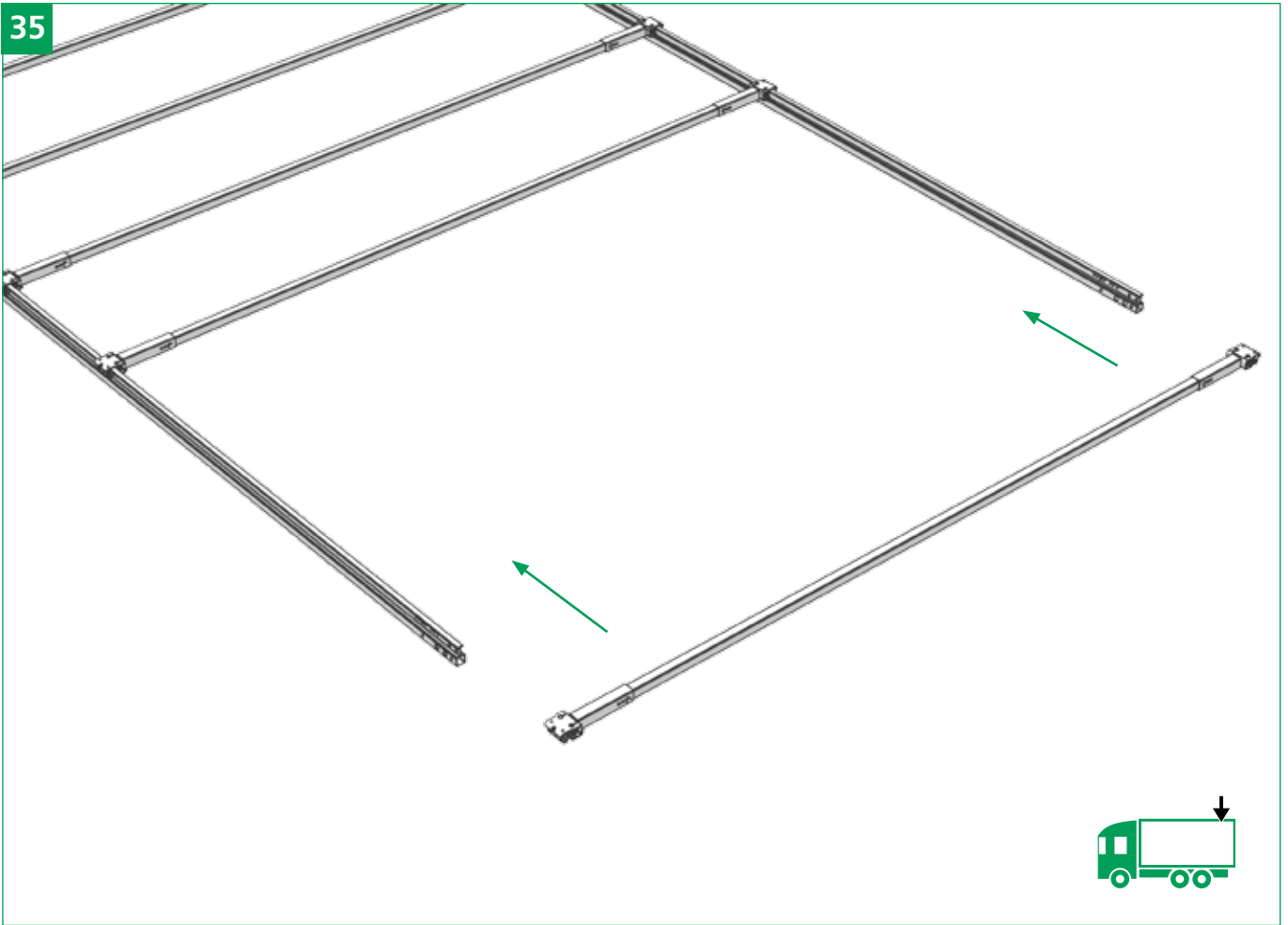

Mount bows

36

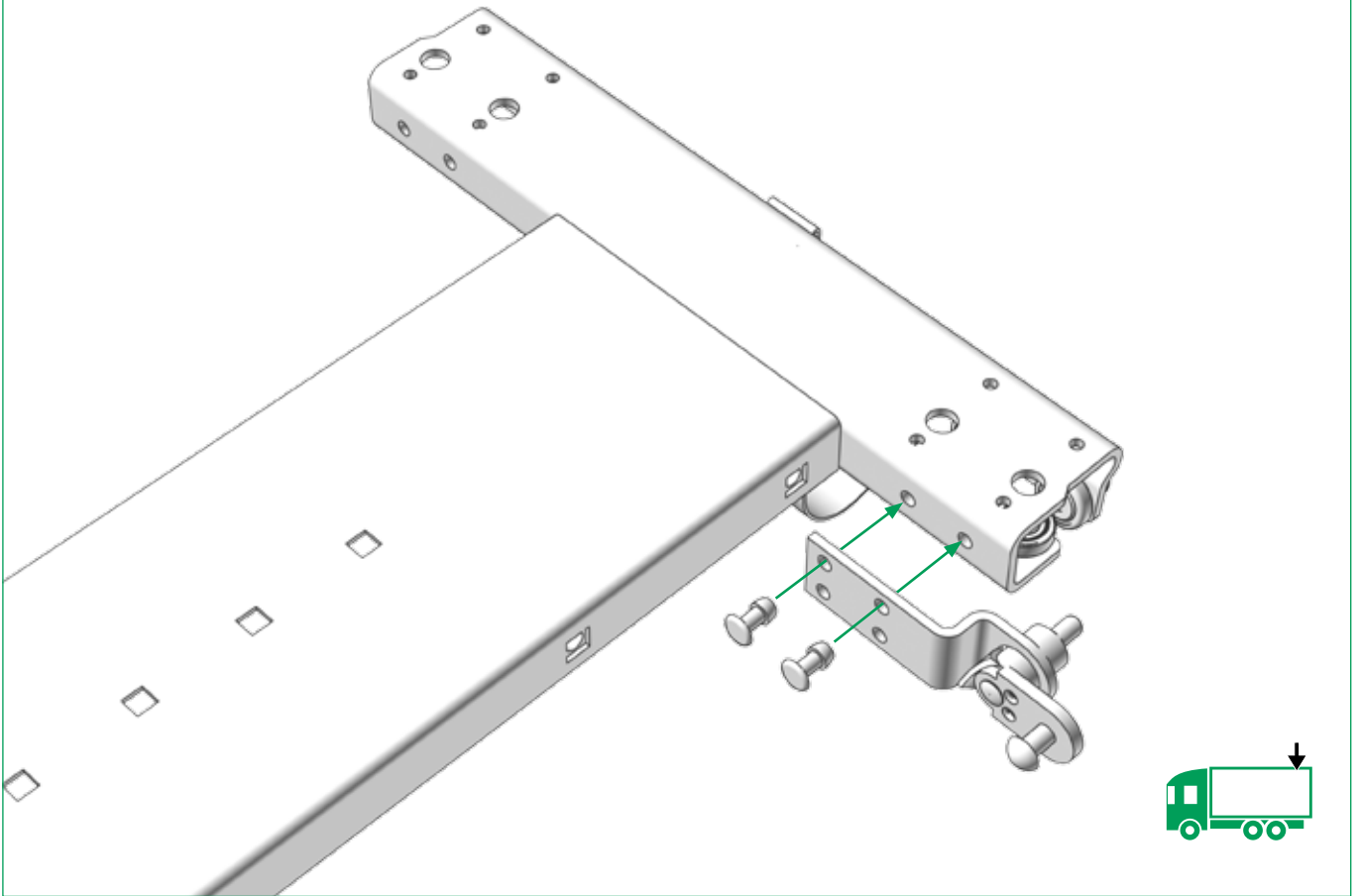

Preassemble end carriage 01

Carry out process on both sides

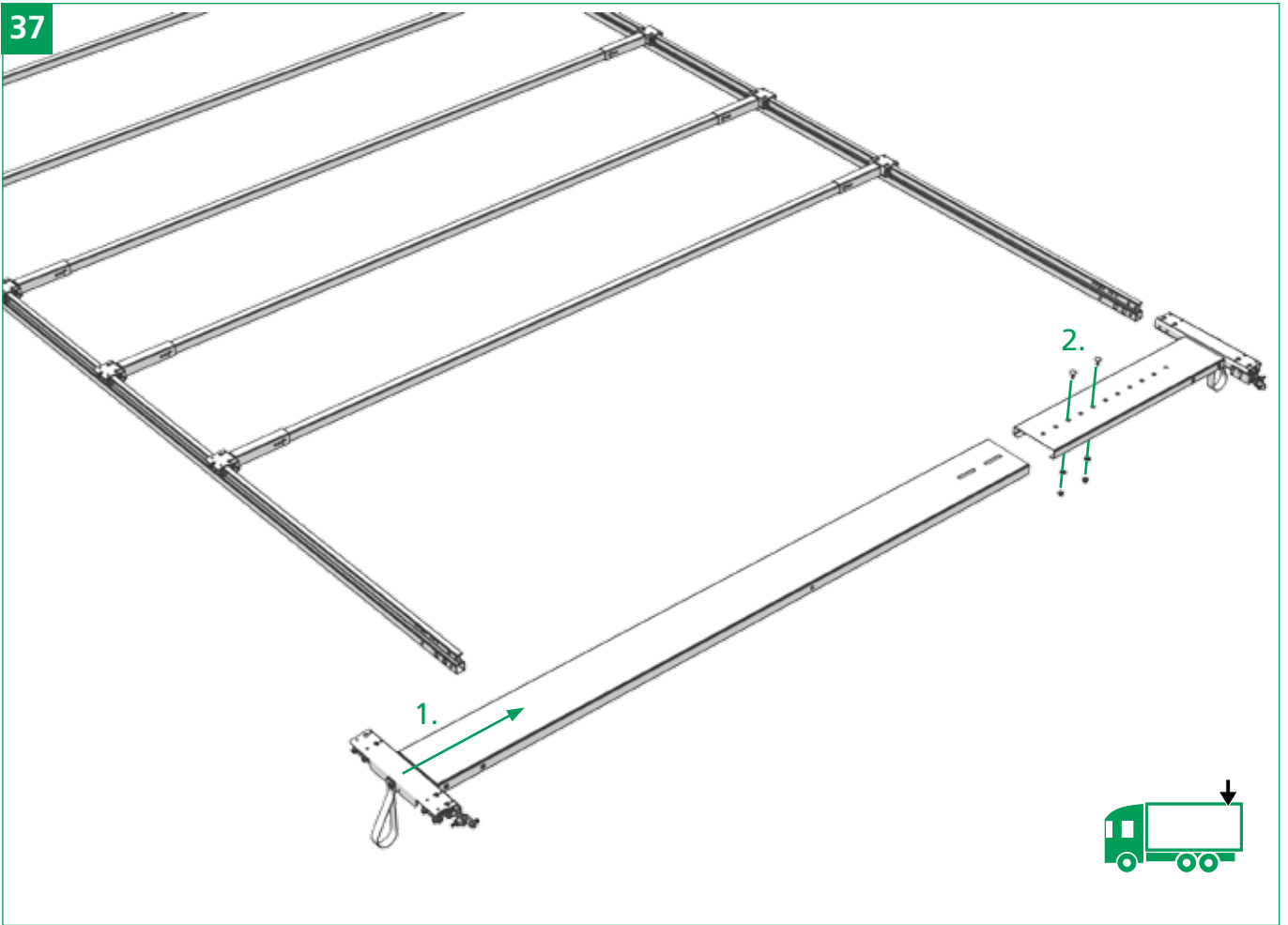

Preassemble end carriage 02

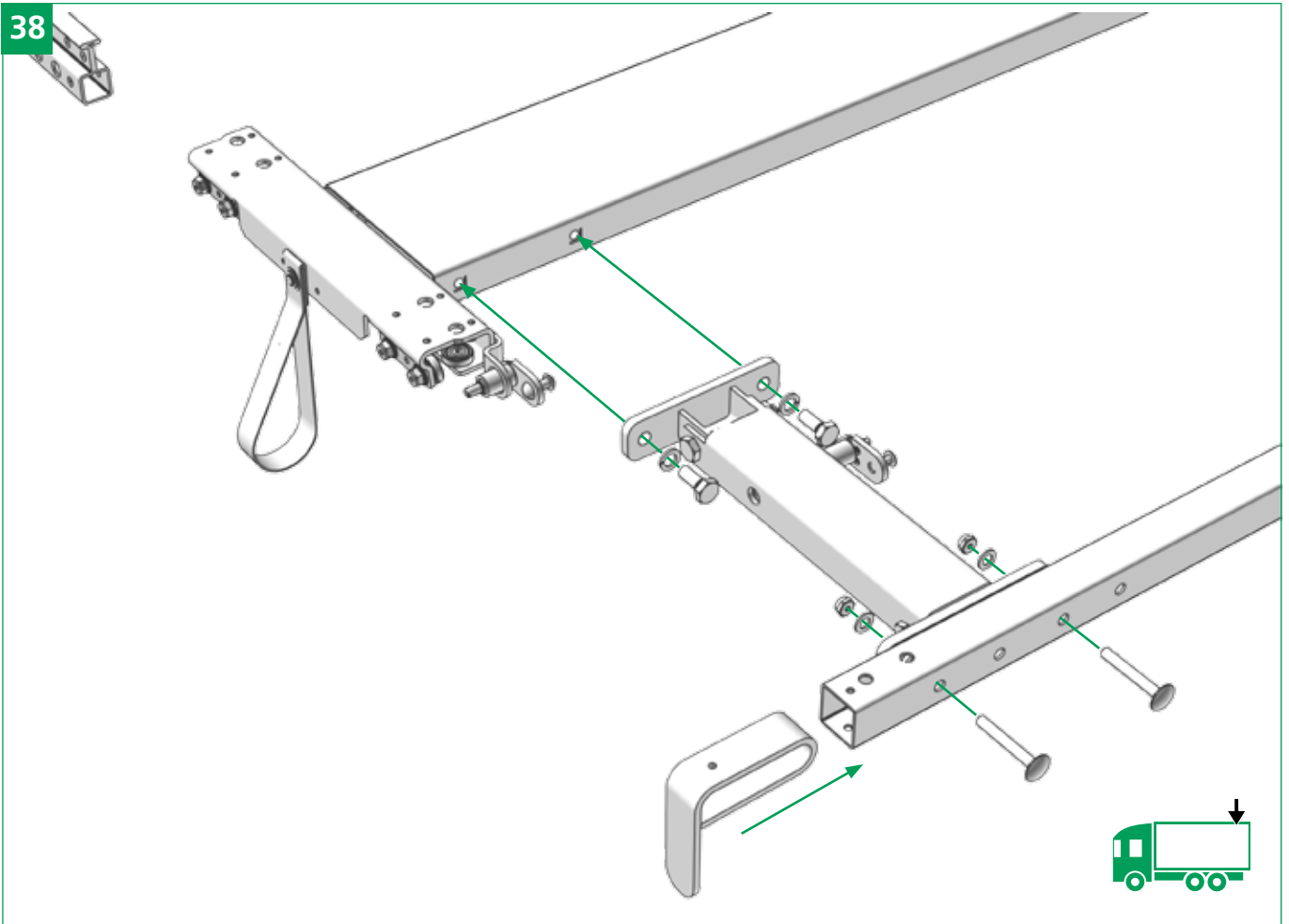

Preassemble end bow

Carry out process on both sides

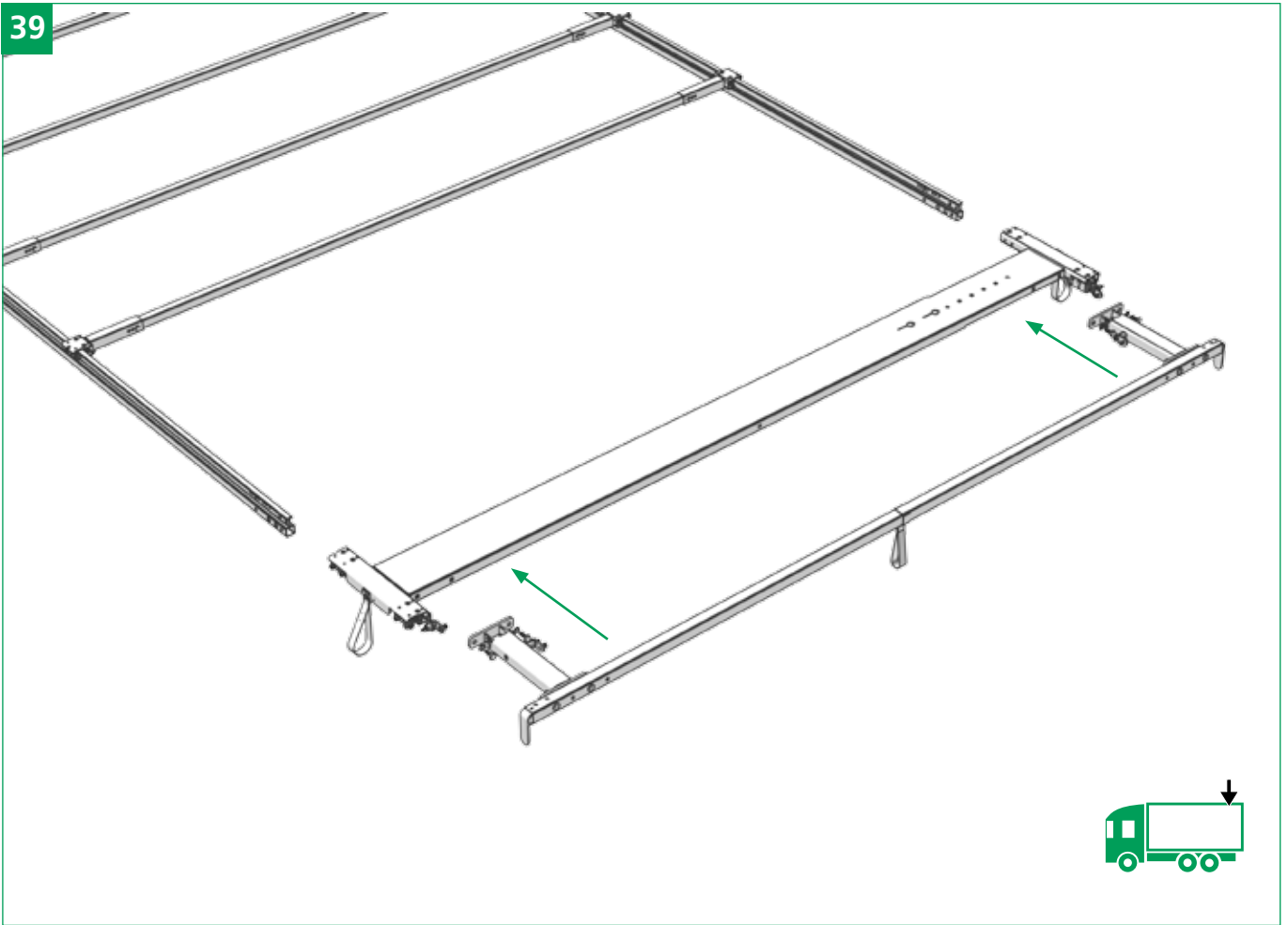

**Preassemble end carriage /
end bow (for use with tarpaulin back cover)**

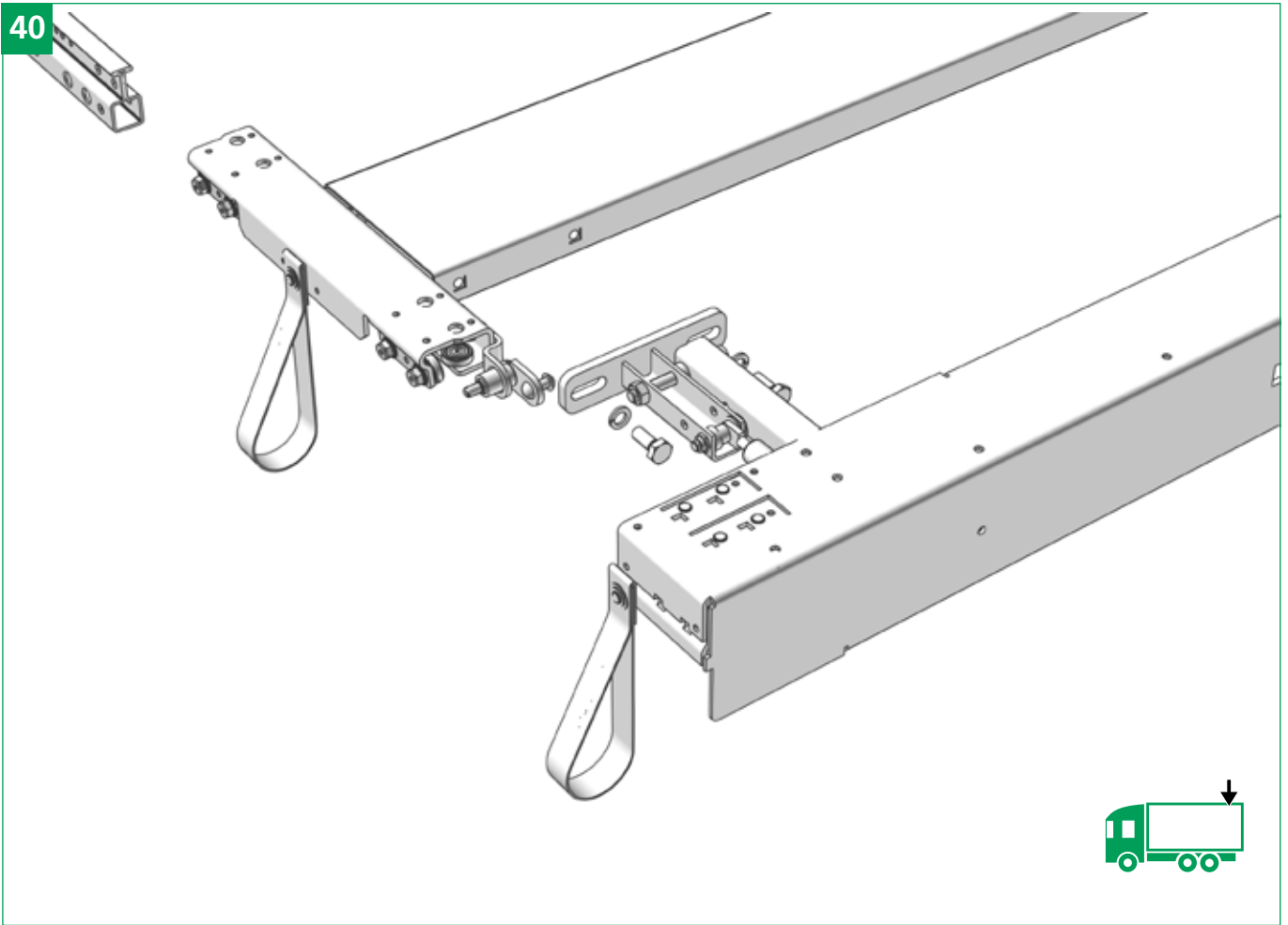

**Preassemble end carriage /
gantry beam (for use with doors)**

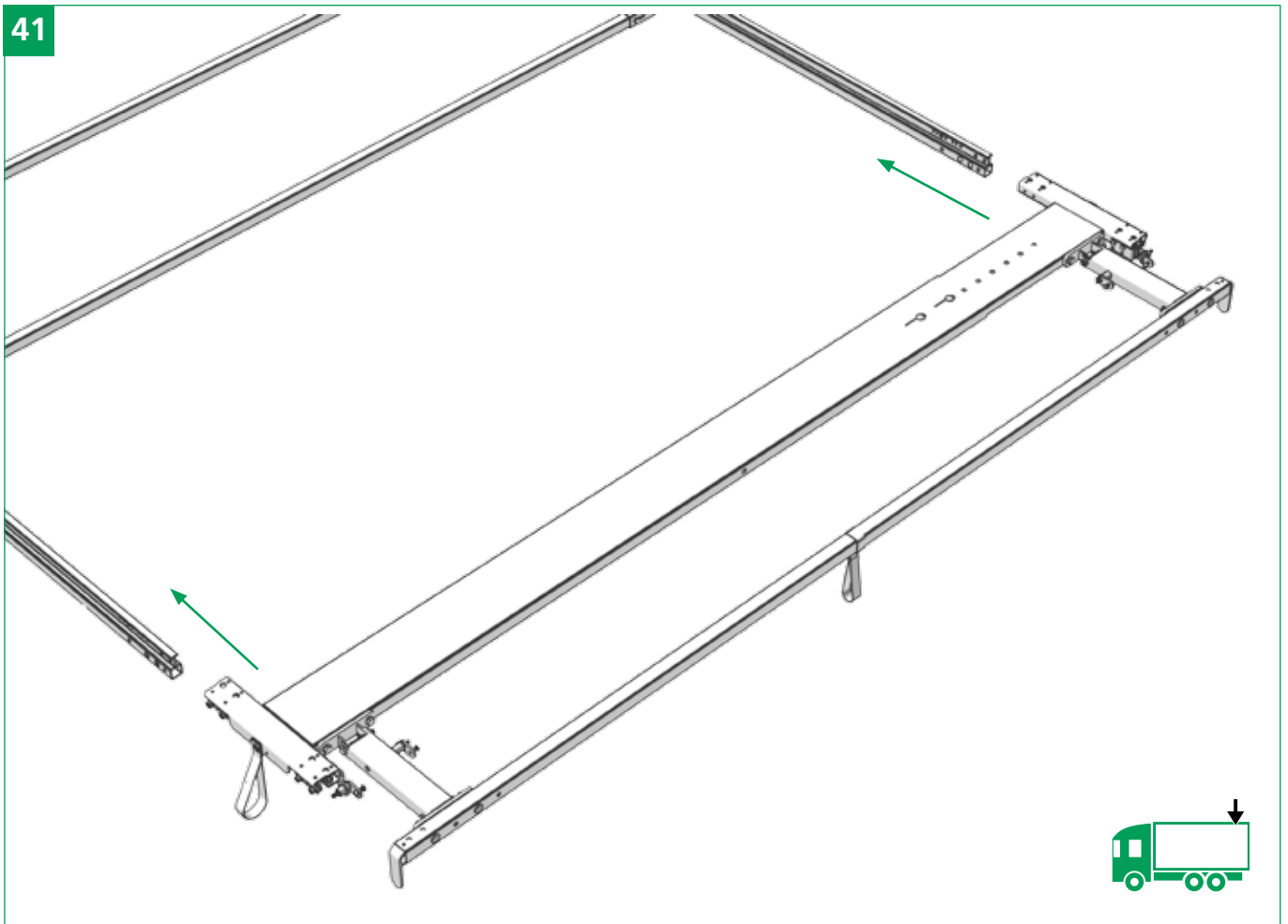

Slide up end carriage

Push the pre-assembled end carriage into the provided chambers of the running rail profiles.

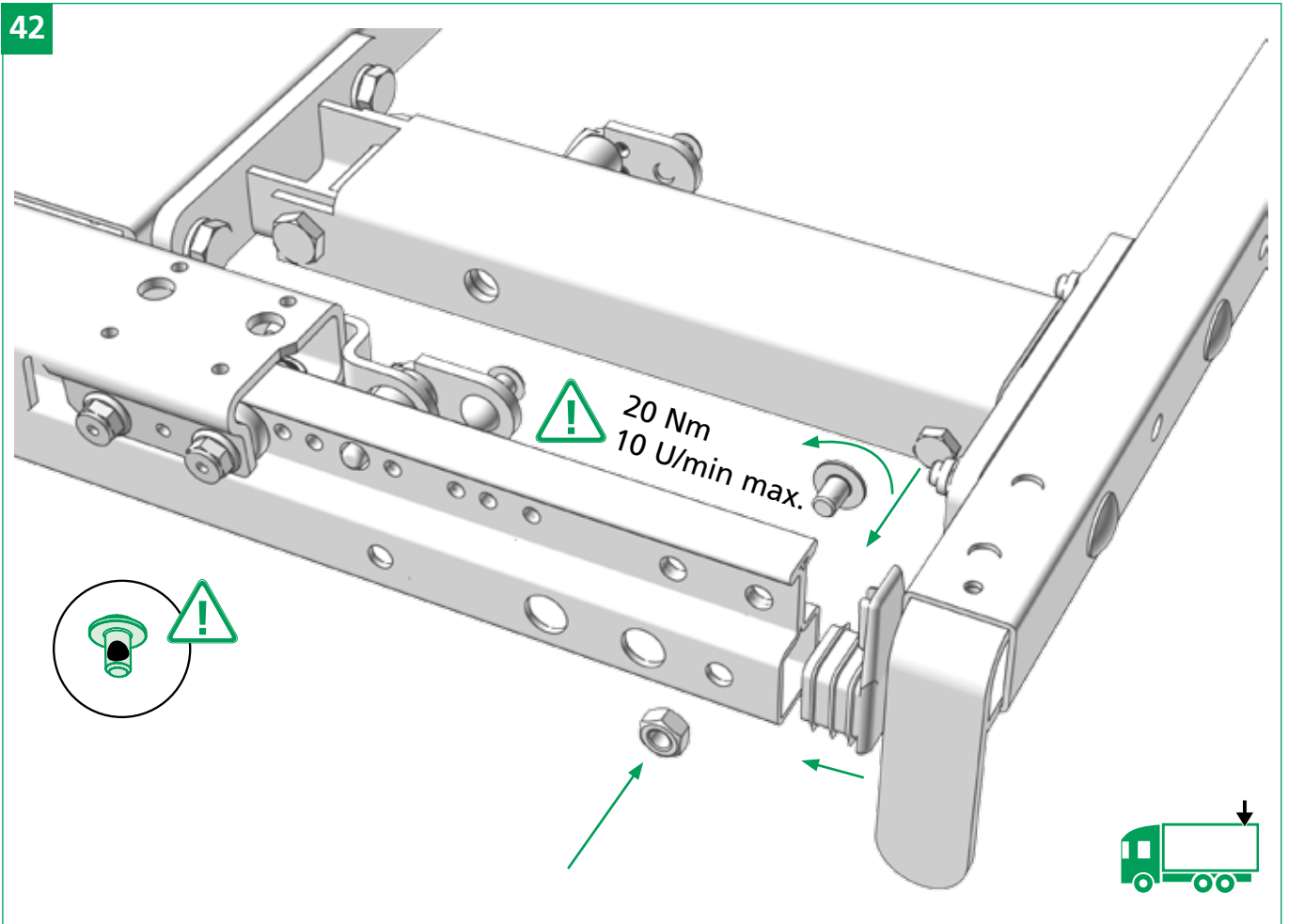

End plug / stopper

Carry out process on both sides

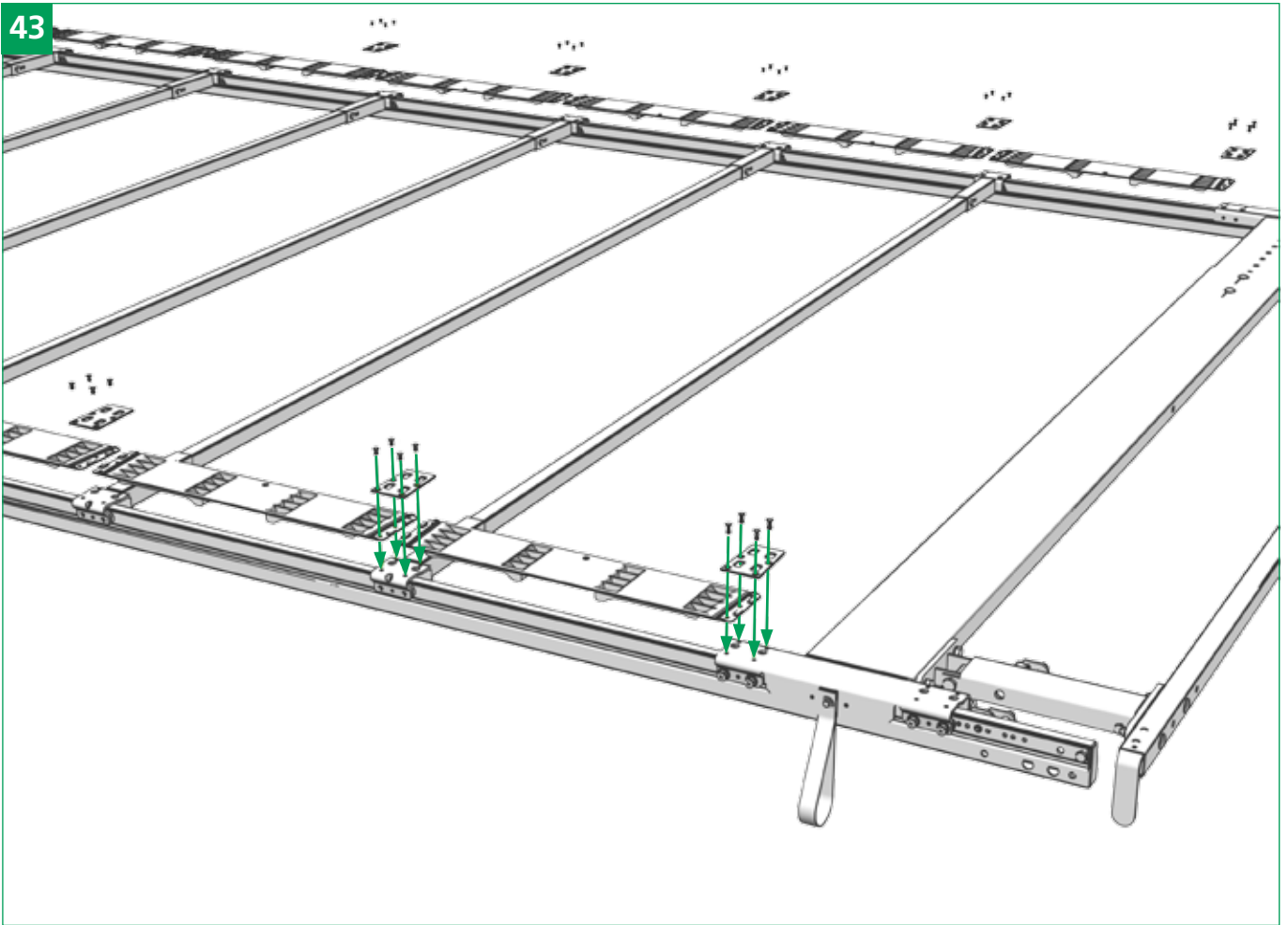

Rivet folding joints

44

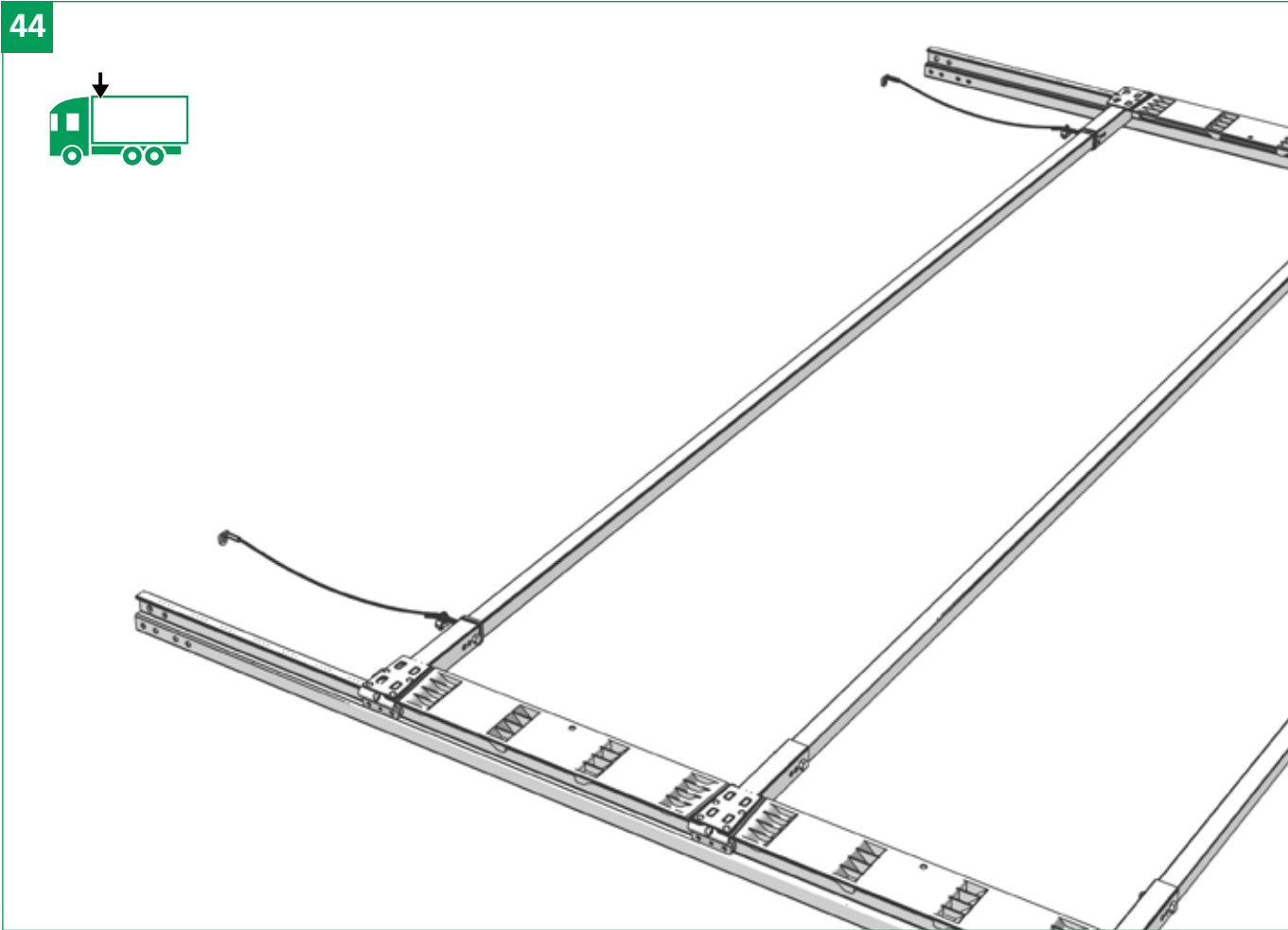

Mount safety rope

Must be securely connected to vehicle bulkhead

45

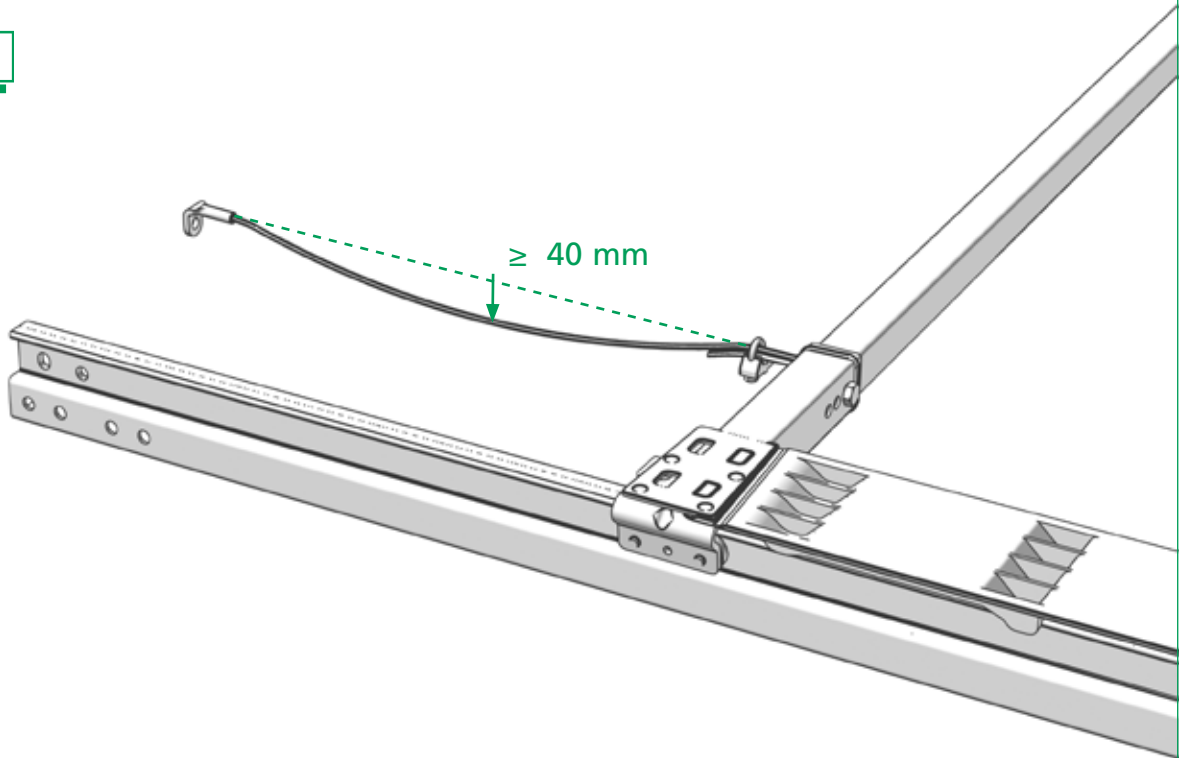

Safety rope – tension

Carry out process on both sides

46

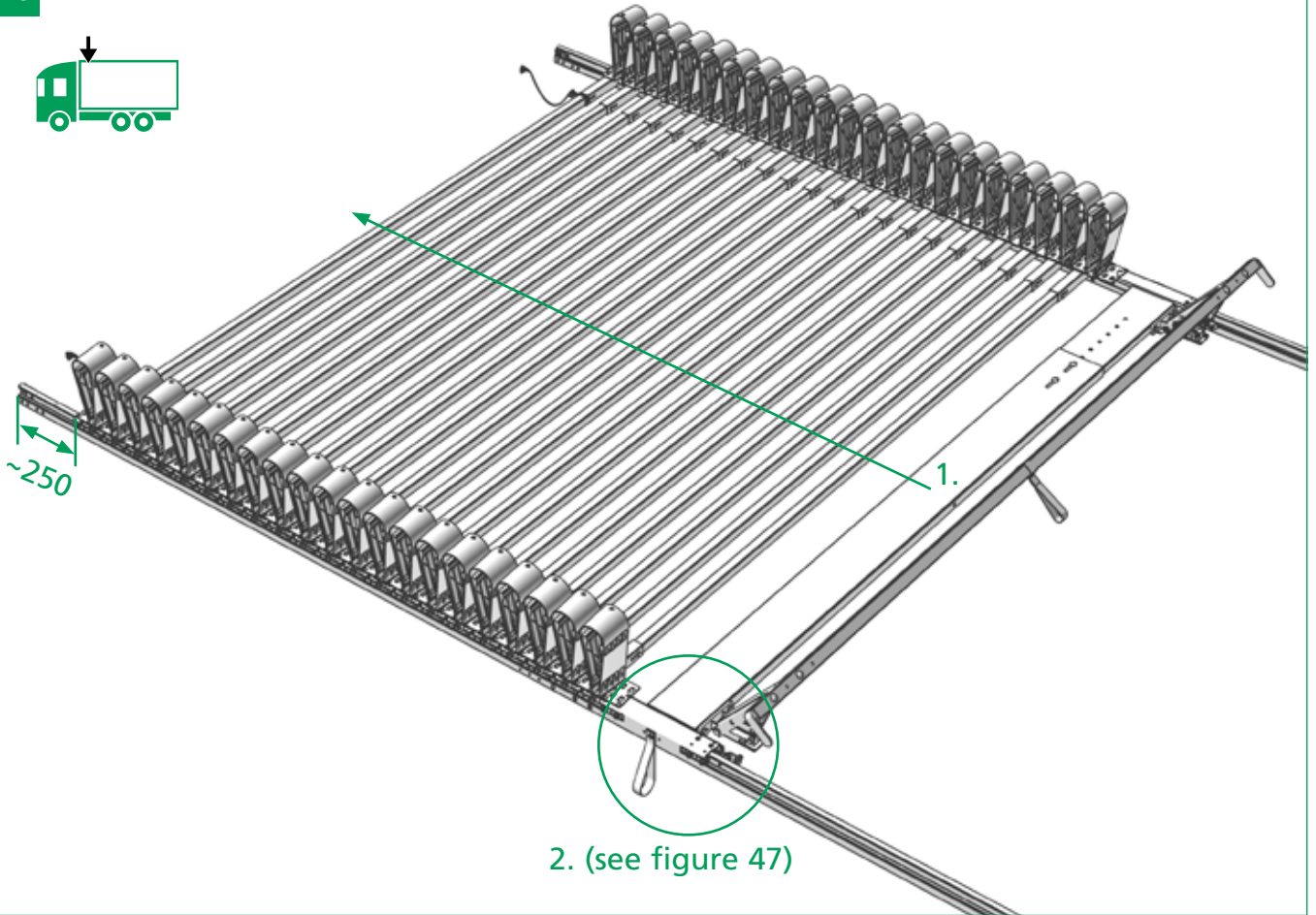

Build roof package

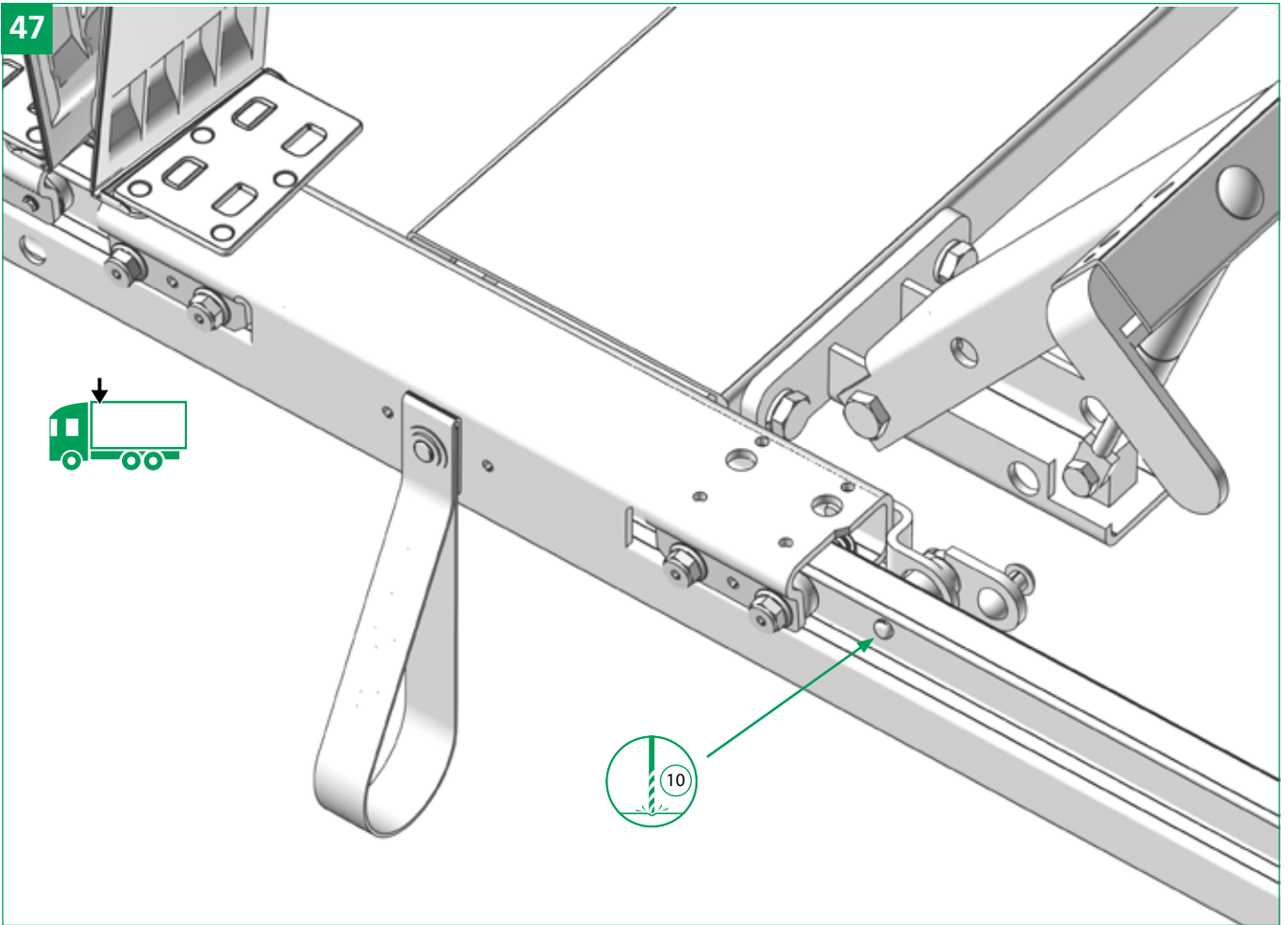

Drill front locking hole

48

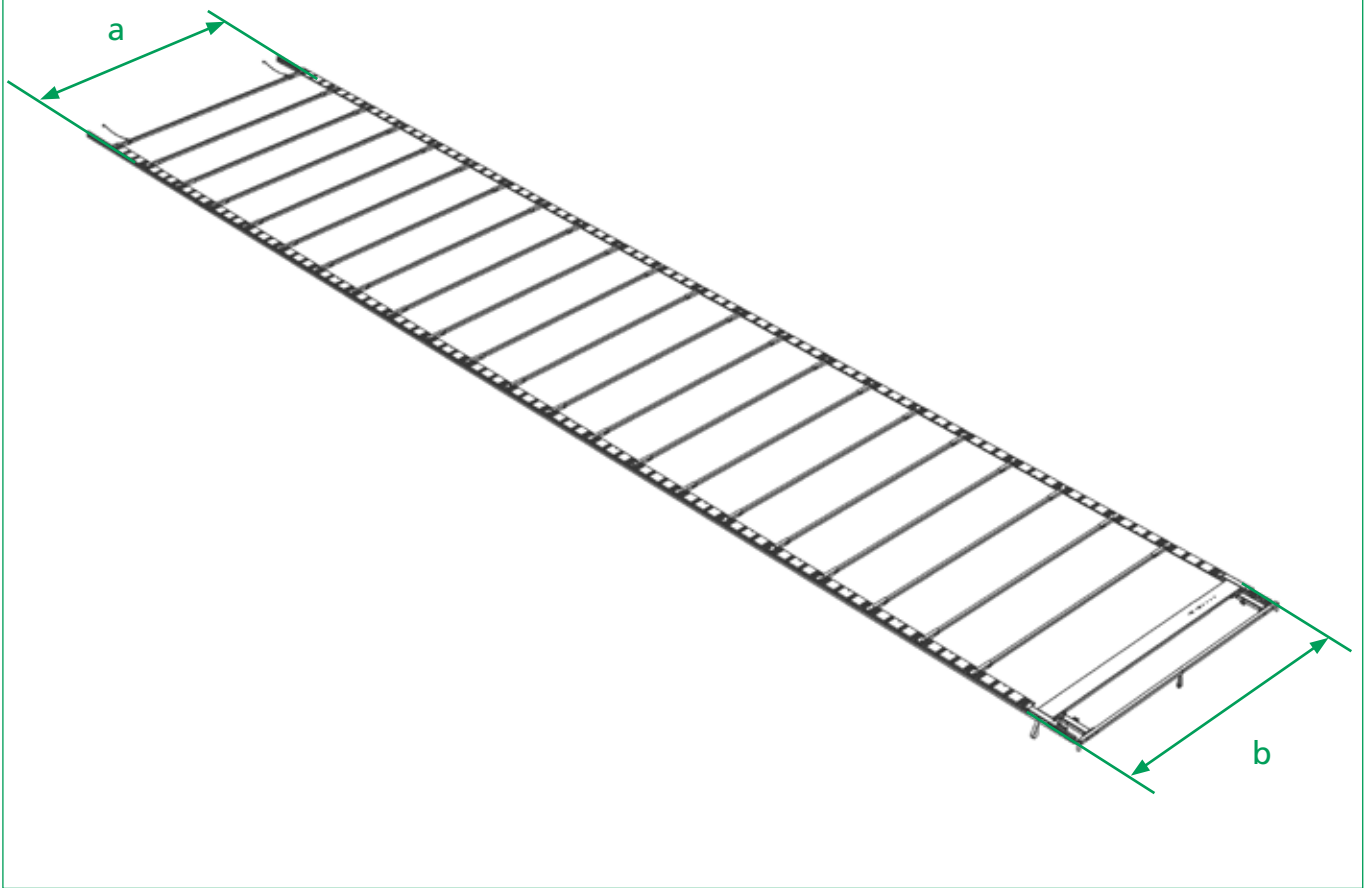

Roof mounted

Difference measurement 'a' to 'b' when closed $\leq \pm 2$ mm.
All bows and the end carriage must have the same width within a tolerance of ± 2 mm in order to allow perfect running of the roof.



Structural components side curtains

Post position

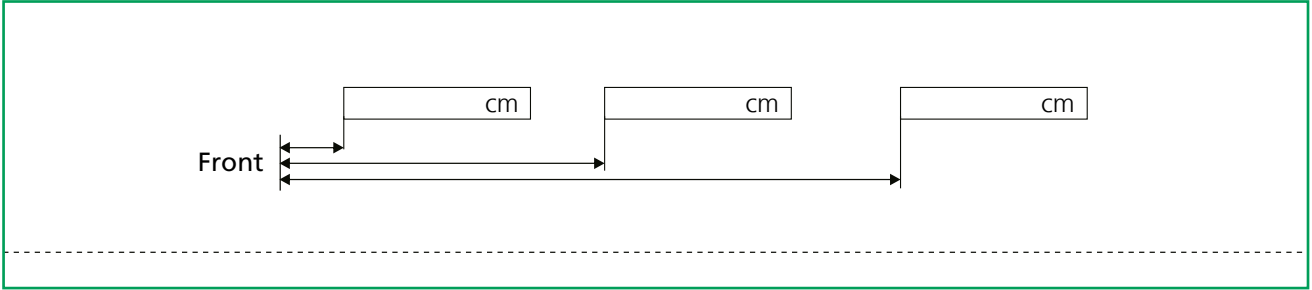

Distance between tarpaulin eyelets with expander cable from the front

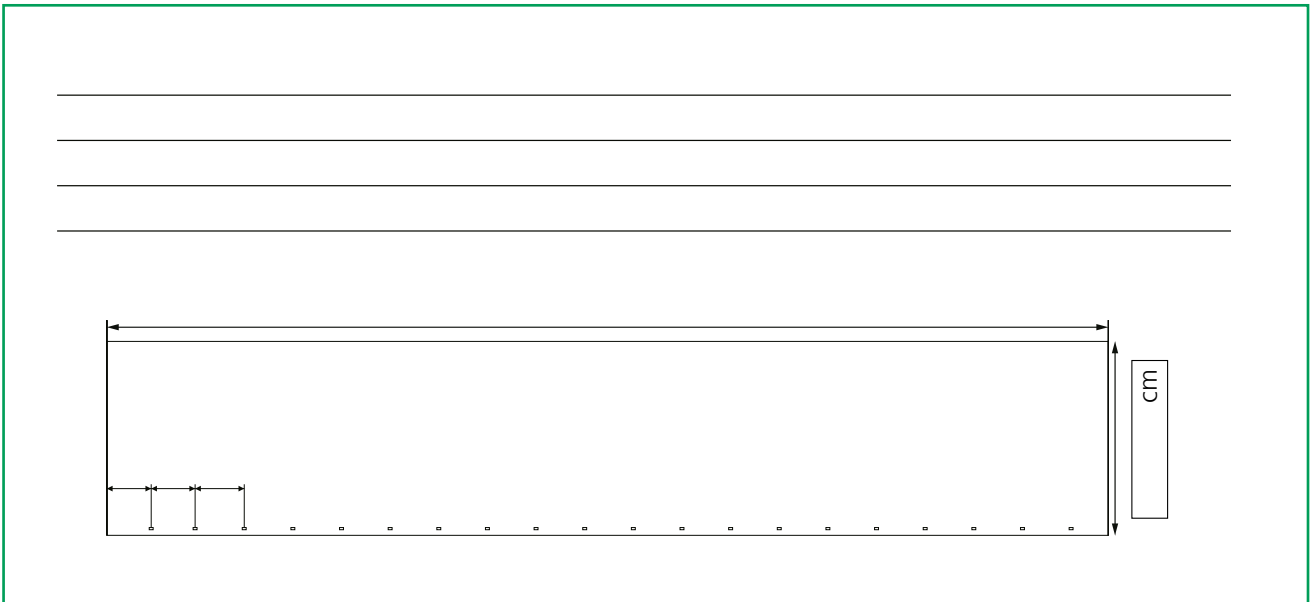

Length and width of roof

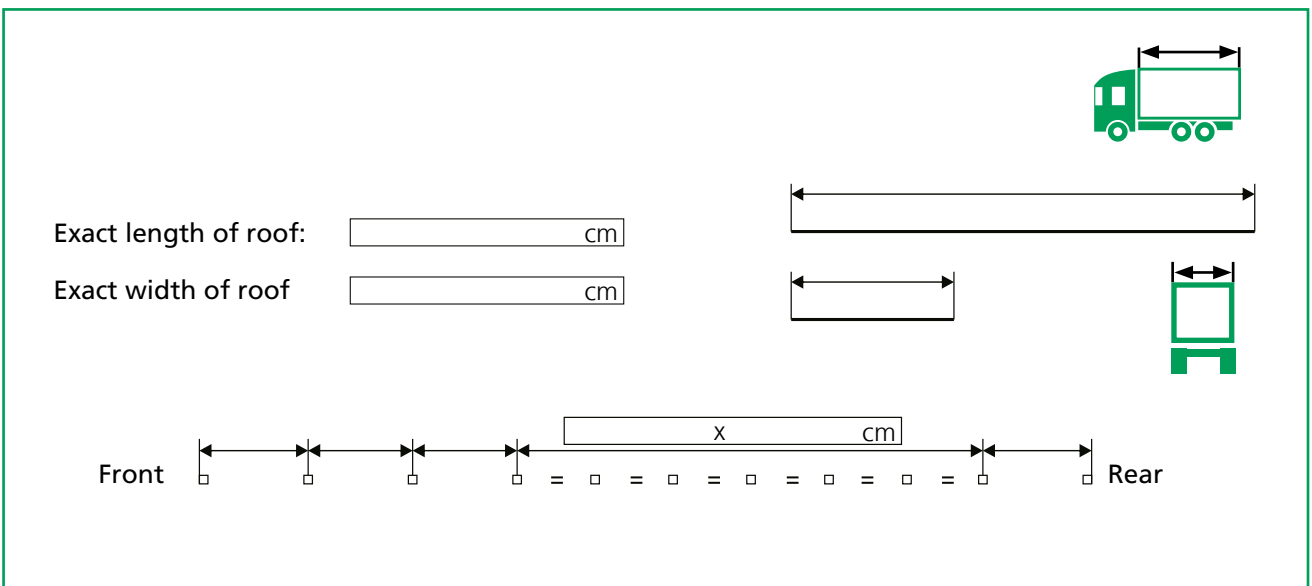



Your sales partner in India:

European Trailer Systems

c/o RINGFEDER POWER TRANSMISSION INDIA PRIVATE LIMITED
Plot No. 4, Door No. 220, Mount-Poonamallee Road, Kattupakkam,
Chennai – 600 056, India
Phone: +91 (0) 44-2679 1411 · Fax: +91 (0) 44-2679 1422
E-mail:sales.india@EdschaTS.com

European Trailer Systems GmbH

Im Moerser Feld 1f, 47441 Moers, Germany
Phone: +49 (0) 2841 6070 700 · Fax: +49 (0) 2841 6070 333



Das Original

Member of VBG Group

www.EdschaTS.com